

I/727458/2024

उप महाप्रबंधक (एमएम),
का मुख्य महाप्रबंधक दूर संचार,
आं.प्र. दूर संचार परमंडल, तीसरा तल,
बी.एस.एन.एल भवन, वजयवाडा
Dy. General Manager (MM)
O/o CGMT, AP Circle, R No:310, 3rd Floor,
BSNL Bhavan, Vijayawada – 520004.
Ph : 0866-2444066, dgmmmcovj@gmail.com, sdetenderscovj@gmail.com



भारत संचार निगम लिमिटेड
(भारत सरकार का उद्यम)
BHARAT SANCHAR NIGAM LIMITED
(A Govt. of India Enterprise)

NIT No. APCO-23/11(13)/26/2024-MM AND IT

DATED 23/08/2024

To

The Prospective Bidders

BID DOCUMENT

E-Tender document for **Laying PLB pipe/ Duct and Associated works by Open Trench Method/Trenchless Technology, Optical Fibre Cable Pulling/Blowing and splicing works etc., for Sri City Check post BBNL BJC- Post Office Sri City BSNL BJC, in Chittoor BA, A.P-517501.**

Part A-QUALIFYING BID

<p><i>Particulars of Payment of Price of Tender Document:</i></p> <p>Demand Draft no/ Transaction Id/ Receipt no</p> <p>----- dated -----</p>
<p><i>Particulars of EMD:</i></p> <p>Demand Draft no/ Transaction Id/ Receipt no/EMDBGNo.</p> <p>BID DOCUMENT</p>

Date of Tender Opening: 17/08/2024

Validity of bids: 180 days

TABLE OF CONTENTS**Part-A: Qualifying Bid**

Section	Contents	Page No
	Cover Page	1
	Table of contents	2
I	Notice Inviting Tender (NIT)	3-6
II	Bid Form	7
III	<u>Tenderer's Profile</u>	8 - 9
IV	<u>Instruction to Bidders</u>	10-22
V	<u>General (Commercial) conditions of the contract</u>	23-47
VI	<u>E-tendering Instructions to Bidders</u>	48-53
VII	<u>Special conditions of the contract</u>	54-70
VIII	<u>Important Instructions</u>	71-73
IX	<u>Scope of the Work and jurisdiction of contract</u>	74-76
IX Annexure-I	<u>Detailed Route Diagrams for works to be done under the sections</u>	77
X	<u>Material Security Bond Form</u>	78-79
	Proforma for Bid Security/EMD guarantee and Performance Bank Guarantee (PBG)	80-83
XI	<u>Proforma of Agreement</u>	84-85
XII	A. <u>Standard Schedule of Rates for OFC laying (UG).</u> B. <u>Standard Schedule of Rates for OFC laying .(OH)</u>	86-94
XIII	<u>Optical Fibre Cable Construction Specification Manual.</u>	95-115
XIV- Annexure-A to E	<u>Proforma of No Near Relative Certificate, Non-Black listing declaration, Clause-by-Clause Compliance statement, No deviation statement, Undertaking & Declaration</u>	116-119
XV- Annexure-B	<u>Proforma of Experience Certificate</u>	120
XVI- Annexure -C	<u>Declaration of Genuineness of documents</u>	121
XVII	<u>Sample Application of Depth Deviation</u>	122
XVIII	<u>Rate of empty cable drum</u>	123

Part-B Financial Bid

Section	Contents	Page No.
XIX	<u>Section Wise Schedule of Quantities And Estimation of Cost of Works Put To Tender</u>	124
XX	<u>Schedule for Quoting the Rates</u>	125
Annexure	Annexure-1 (Deed of Indemnity), 2 (Check list for the bidders)	126-130

SECTION-I



Bharat Sanchar Nigam Limited
(A Govt. of India Enterprise)
O/o CGMT, BSNL BHAVAN, VIJAYAWADA-520004
Tel No- 0866-2444367

Notice Inviting Tender

NIT No APCO-23/11(13)/26/2024-MM AND IT DATED 23/08/2024

Digitally sealed online tenders [E-tenders (Digitally Signed)], on rupee payment basis are invited by AGM(Tenders), O/o CGMT, CO VJ in Single Stage Bidding and Two stage Opening using two Electronic Envelopes [Techno-Commercial (Qualifying Bid) & Financial Bid] for and on behalf of CGMT, AP, BSNL from the experienced contractors, for the following works:

Name of the works:

Laying PLB pipe/ Duct and Associated works by Open Trench Method/Trenchless Technology, Optical Fibre Cable Pulling/Blowing and splicing works etc., for Sri City Checkpost BBNL BJC- Post Office Sri city BSNL BJC , in Chittoor BA, A.P-517501

1. Scope and Jurisdiction of Work: The scope and particulars of work put to tender are given in the Table below:

Sl. No	Name of the Section	Type of the Work	Approx. Route Length in meter	Tender Estimated Cost per meter (in Rs.) (Excl. of GST)	Estimated cost of works (in Rs) (Including GST)	Time Period in days	Bid Security / EMD (in Rs)	Price of Bid Document (in Rs)
1	Sri City Checkpost BBNL BJC- Post Office Sri city BSNL BJC in Chittoor BA	Open Trenching	1000	200.12	2,36,141.6/-	42	16,700/-	590/-
		HDD	1100	400	5,19,200/-			
		Other allied OFC works		SOR	77,615.68/-			
		Section 1 Total						
	Section 1 Total length of OFC route		2100 m					

Note-1: BSNL reserves the liberty to cancel the route, change the location, to modify the length of the section depending upon the condition at the time of issuing work order. The route lengths mentioned above are approximate. Bidders are expected to survey the route and quote the rates accordingly.

Note-2: The quantities stipulated in the tender are estimated and the BSNL reserves the right to vary the value of works to the extent of -25% to + 25% of contract value during contract period at the same rates and terms & conditions with prior approval of the tender approving authority. However, **in exceptional circumstances only**, due to change in scope of work or otherwise, any variation in the value of work may be permitted up to 50% of contract value with prior approval of the next higher authority after recording adequate reasons and justification for the same.

Note-3: Bidders who have been rescinded /debarred by Tendering authority/Higher BSNL Unit as the case may be including for reasons for failing to sign necessary agreement with the concerned Tendering authority in stipulated time on earlier occasions, will not be eligible to participate in the tender for the same work.

Note-4: For participating in e-Tendering process bidder shall access e-Bid document uploaded on the e tender portal and pay requisite tender processing fee as defined for the tender.

Note-5: Multiple PLB pipes are to be laid in the same open trench/HDD if required as decided by the in-charge of the work in the same trench whole or part of the length of the section without any additional payment for trenching. However, the laying charges (prefixed) of additional PLB/DWC/GI will be paid for open trench.

Note-6: Measurement of the work of cable pulling/blowing through pipe/duct will be taken equal to the length of the pipe / duct through which the cable has been pulled and not the total length of the cable pulled through pipe/duct (Length of the Cable Coils kept in Loop/Joint Chambers are not considered for measurement).

Note-7: A bidder can participate in any number of sections mentioned in this tender. If bidder want to participate in more than one section, he/she has to submit their price bids section wise. Bidders who have been rescinded /debarred by Tendering authority/Higher BSNL Unit as the case may be including for reasons for failing to sign necessary agreement with the concerned Tendering authority in stipulated time on earlier occasions, will not be eligible to participate in the tender for the same work

Note-8: All the subsections under a Section are treated as Single Section only.

2. **Eligibility Criteria:** For participating in the tender, the tenderer should meet the following eligibility criteria:

(i) The tenderer who possess experience of having successfully completed the **Optical Fibre Cable Construction works** in BSNL/MTNL/TCIL/ ITI/Rites/Hindustan Cables Limited (HCL)/ PGCIL/ Rail Tel/ any other Govt. (Central/ State) undertaking/ any other TSP/ISP's having mandate to carry out OFC construction work or the PSUs directly themselves and who also have received the payment for such completed works to the extent as mentioned below, are eligible to participate in the tender:

a) For an amount equal to at least 90% of estimated cost of work put to tender during last 5 Financial years plus the subsequent period ending the month preceding the one in which NIT is issued.

OR

b) For an amount equal to at least 120% of estimated cost of work put to tender during last 7 Financial years plus the subsequent period ending the month preceding the one in which NIT is issued.

(ii) The tenderer whose near relative(s) is/are employed in BSNL, is not eligible to participate in the tender, as per limitations mentioned in Annexure-A.

(iii) Contractor should have the valid EPF registration certificate on the date of issue of NIT.

(iv) Contractor should have the valid ESI registration certificate.

I/727458/2024

- (v) Contractor should have the valid GSTIN registration certificate.
- (vi) The bidder should have Valid PAN No.
- (vii) A self- declaration along with the evidence that the bidder is not blacklisted by any Central/ State Government/ agency of Central/ State Government of India / Public Sector Undertaking/any Regulatory Authorities in India/BSNL/MTNL/TCIL/ITI/RITES/HCL/PGCIL/RailTel/GST/any other TSP/ISP for any kind of fraudulent activities.
- (viii) In case of multiple GST numbers, all the numbers to be provided as Annexure
- (ix) In the case of MSE (Micro and small enterprises) units the bidder should declare UAM number (Udyog Aadhar Memorandum) on CPPP portal. The bidders who fail to submit UAM number shall not be able to avail the benefits (exemption from tender fee and EMD) available to MSEs as contained in Public procurement policy for MSEs order, 2012 issued by MSME. The undertaking regarding submission of UAM number on CPPP portal is to be uploaded online.

Note 1: The experience of having successful completion of OF cable construction works is to be reckoned in terms of payment received for such works during the above said periods.

Note 2: The Experience should be of Optical Fibre Cable construction work only and does not include any other work like Pole less /Up-gradation/Maintenance works of OFC/External Plant/ UG Cable (Copper) etc.

Note 3: The experience certificate for carrying out the works and amounts received should be in the prescribed pro-forma and the certificate should be under the signature of officer responsible for maintaining the contractor's ledger e.g. Asst.GM/AO (Cash)/DDO or equivalent officer of the concerned PSU i.e. BSNL/ MTNL/ TCIL/ ITI/ Rites/ HCL/ PGCIL/ Rail Tel/ any other Govt. (Central/ State) undertaking/TSP/ISP as the case may be. In case of any other TSP/ISP the date of Experience certificate should not be older than 3 months from the date of this NIT.

Note 4: In case, supplier gets black-listed during the tenure of BSNL contract, then BSNL has the right to recover the Input Credit Loss suffered by it due to any default by the vendor.

Note 5: Of late, big Govt. contracts are being carried out by the Public Sector Undertakings mentioned herein through a chain of contractors. In such case, the experience certificate, if issued, in favor of a contractor, in the chain, by such PSUs in the prescribed format shall be acceptable.

3. Period of contract: The period of this contract will be **one year** from the date of agreement. However, the BSNL reserves the right to extend the contract further, in terms of six months or less, up to one year on the same rates, terms & conditions, which shall be binding on the contractor.

4. Date of sale of tender document, Last date of submission of bid, Date of opening of Bids:

Availability of tender Document Online on e-tendering portal	Deadline for Submission of		Date & Time of opening of Physical Envelope	Date of Opening of Bids Online	
	e- Bids Online on e-tendering portal	Physical Envelope to BSNL (office name)		Qualifying Bid	Financial Bid
FROM 23/08/2024 To 11/09/2024 Up to 10.00 hrs	Up to 10:00 hrs of 11/09/2024	Up to 11:00 hrs of 12/09/2024	At 11:00 hrs on 12/09/2024	At 11:00 hrs on 12/09/2024	To be notified later

Note: The Price of bid document along with GST shall not be refundable.

5. If the date of opening of the bids happens to be holiday, the tenders will be opened on the next working day at the same time and the same venue.

6. The tender is invited through **e-tendering process** through the e-tender portal (<https://etenders.gov.in/eprocure/app>). Kindly refer Section-VI of Tender document for further

I/727458/2024

instructions on e- tendering. Prospective bidders should get their registration done well in time on the e-tender portal and obtain the Digital Signature Certificate (DSC) from authorized CA, which is essential for participating in the tendering process. This link can also be visited using our website i.e. <http://tender.bsnl.co.in>, (by clicking the link for e-tendering the home page).

7. Tender will not be accepted/received on the e-tendering portal after due date and time. The officer in charge BSNL reserves the right to reject any or all tenders without assigning any reason whatsoever.

8. As the tender is invited through e-tendering process, physical copy of the tender document would not be available for sale. The bidder needs to download the tender document using the link as mentioned above.

9. All the documents in Qualifying Bid –Part-A and Financial bid-Part B are to be uploaded in the respective electronic envelopes/parts on e-tender portal including proof of deposit of cost towards e- payment (RTGS/NEFT)/DD/Banker's Cheque/ towards cost of tender and e-payment (RTGS/NEFT)/DD/Banker's Cheque /BG towards EMD.

10. Last date and time of submission of tender document:

Date & Time of submission of Tender bids online as per clause 4. **Envelope containing offline document** should be submitted by the bidder to the office address: AGM(Tenders), BSNL, R NO:311, BSNL Bhavan, Chuttugunta, Vijayawada-520004 as per **Section-VI, clause 5**, failing which the tender bid if already opened on basis of scanned copies uploaded in Technical envelope will be rejected.

11. The units registered under single point registration scheme of NSIC /MSE units for OF Cable laying works are exempted from depositing the price of tender document and from payment of earnest money deposit (EMD). Such bidder shall have to upload the document in proof of registration of valid NSIC/MSE for carrying out OFC work along with bid document.

12. The successful bidder including NSIC/MSE bidder shall submit Performance Bank Guarantee (PBG) & material security (BG) as per Section-V of clause 5 as per letter of intent.

- The Bid Security/EMD & Performance Security shall be paid in the form of Bank Guarantee/ DD from any nationalized/scheduled bank of the Reserve Bank of India, drawn in favour of **AO(CASH) , O/o CGMT , BSNL , Vijayawada.**

The Cost of Bid Document should be paid in the form of demand draft/Banker Cheque or paid through online payment mode vide details:

**Customer Name:ACCOUNTS OFFICER (CASH), SBI Account number: 39219700053
IFS code: SBIN0003723**

Address of the Bank: **STATE BANK OF INDIA, MACHAVARAM BRANCH, Vijayawada.**

13. If a vendor registered with body specified by Ministry of Micro, small and medium enterprise claiming concessional benefits (such as exemption from Tender Fee and EMD) is awarded work by BSNL and subsequently fails to obey any of the contractual obligation, he may be debarred from any further work /contract by BSNL for one year from the date of issue of such order and MSME authority issuing the certificate shall also be informed for taking suitable action.

S. No	Name of the Person	Designation	Mobile/contact No	Mail ID
1	A Vara Lakshmi Prasad	AGM Tenders, CO VJ	0866-2444367 M: 9441249979	agmtendersbsnlcovj@gmail.com
2	Lalitha D	AGM(Plg)	9444979820	agmplgctr@gmail.com

Asst General Manager(Tenders)
O/o CGMT, BSNL, Vijayawada

----- END OF SECTION-I -----

I/727458/2024

SECTION II BID FORM

NIT No: APCO-23/11(13)/26/2024-MM AND IT DATED 23/08/2024

To
The CGMT,
BSNL, Vijayawada.

Dear Sir,

Having examined the terms & conditions of bid document and the specifications including Addendum/Corrigendum (if any), the receipt of which is hereby duly acknowledged, we, the undersigned, hereby submit our offer to execute the works of **Laying PLB pipe/ Duct and Associated works by Open Trench Method/Trenchless Technology, Optical Fibre Cable Pulling/Blowing and splicing works etc., for Sri City Check post BBNL BJC- Post Office Sri City BSNL BJC, in Chittoor BA, A.P-517501**

stipulated against this NIT in conformity with said drawings, terms & conditions of contract and specifications.

We undertake, if our Bid is accepted, we will execute the work in accordance with specifications, time limits & terms and conditions stipulated in the tender document.

If our Bid is accepted, we shall submit the securities as per the conditions mentioned in the contract.

We agree to abide by this Bid for a period of 180 days from the date fixed for Qualifying Bid opening and it shall remain binding upon us and may be accepted at any time before the expiry of that period. Until a formal Agreement is prepared and executed, this Bid together with your written acceptance thereof in your notification of award shall constitute a binding contract between us.

Bid submitted by us is in full compliance of the requirements of e-tendering.

Dated this day of(the year)

Signature of Authorized Signatory

.....

In capacity of

.....Duly authorized to sign the bid for and on behalf of

.....

Witness

Address

Signature

----- **END OF SECTION-II** -----

**SECTION III
TENDERER'S
PROFILE**

General:

- 1. Name of the tenderer / firm _____
- 2. Name of the person submitting the tender whose photograph is affixed and who possesses the Digital Signature Certificate (DSC).
 - (a) Shri/Smt _____
 - (b) DSC Issuing Agency.....

Paste Color Passport size photograph of the tenderer / authorized signatory holding power of Attorney and having Digital Signature Certificate. Photograph should be self-attested
--

(In case of Proprietary / Partnership firms/Company, the tender has to be digitally signed by Proprietor /Partner(s)/authorized signatory only, as the case may be)

- 3. Address of the firm

- 4. Correspondence Address

- 5. Tel.no. (with STD code) (O).....
 (Fax).....(R).....

- 6. Mobile No: email-id:
 (Note: These contact details shall be used to communicate with the tenderer / contractor and any communication sent there on shall be taken as proper communications under this contract)

- 7. Registration & incorporation particulars of the firm(Tick as applicable): (i)Proprietorship (ii) Partnership (iii) LLP (iv) Private Limited (v) Public Limited
 (Please attach attested copies of documents of registration/incorporation of your firm with the competent authority as required by business law)

- 8. Name of Proprietor/ Partners/ Directors

I/727458/2024

- 9. Tenderer’s Bank Details:
 - a. Name of Bank.....
 - b. Name of Branch.....City.....
 - c. Branch Code.....
 - d. IFSC Code.....
- 10. Permanent Income Tax Account Number (PAN),
Income Tax circle.....
- 11. EPF registration number.
- 12. ESI registration number.....
- 13. Goods and Service Tax (GSTIN) registration No.....
- 14. Whether Micro or Small Enterprises (MSEs)? (Yes/No):.....
If Yes, the purpose of Business for which registered.
Validity: from..... to.....
Monetary Limit.....
Type of Work

15. Infrastructural capabilities of the bidder:

I. Tools and Machinery infrastructure

- a) Capacity of trenching per day (in meters).....
- b) Capacity of PLB pipe laying per day (in meters).....
- c) Capacity of pulling cable through duct / pipe per day (in meters).....
- d) Availability of HDD machine
(Owned.....Capacity.....
.....
Leased).....Capacity.....

e) Particulars of vehicles available with the tenderer:

Type of Vehicles(s)	Registration number
.....
.....

II. Man power

- f) No of trained supervisors -----
- g) No. of Trained splicers -----
- h) Capacity of engaging mazdoors per day

Place: Signature of tenderer / Authorized signatory.....

Date: Name of the tenderer.....

Seal of the tenderer

----- **END OF SECTION-III** -----

SECTION IV -INSTRUCTIONS TO BIDDERS**A. INTRODUCTION:****1. DEFINITIONS**

- a. President of India:** The President of India means the President of India and his successors.
- b. Government of India:** The Government or Government of India shall mean the President of India.
- c. The BSNL** means Bharat Sanchar Nigam Limited, the company with Chairman & Managing Director and Board of Directors, with Head Quarter at New Delhi.

All references of Department

Chief General Manager

Principal General Manager

Sr. General Manager/ General Manager

Addl. General Manager/ Joint General Manager

Deputy General Manager / Deputy General Manager (Projects) Divisional Engineer /Divisional Engineer (Projects)

Sub Divisional Engineer Junior Telecom Officer Chief Accounts Officer Accounts Officer

Junior Accounts Officer

Including other officers in the BSNL, whatever designations assigned to them from time to time, whomay be the in-charge of direction, supervision, testing, acceptance and maintenance including their successor(s) in the office appearing in various clauses shall be taken to mean the BSNL, an enterprise, under the Ministry of Communications and Information Technology, Government of India.

d. The jurisdiction of GM/Addl.GM/ DGM/DET shall mean the territorial area under their control for the purpose of administration and management of the projects and other associated functions.

e. Representative of GM/Addl.GM/ DGM / DET means Officer and staff under their control for the time being deputed for supervising the work or testing etc.

f. Engineer – in – charge: The Engineer – in – charge means the Engineering Officer nominated by the GM/Addl.GM/ DGM to supervise the work, under the contract. (Minimum Divisional Engineer level officer to be nominated while approving the work order).

g. Site Engineer: Site Engineer shall mean JTO/SDE of the BSNL who may be placed by the work order issuing authority for supervising the work.

h. A/T Unit: A/T unit shall mean Acceptance and Testing unit of the BSNL.

i. A/T Officer: An officer authorized by BSNL to conduct A/T.

j. The words bidder and tenderer have been used interchangeably.

k. Contract: The term contract means, the documents forming the tender and acceptance thereof and the formal agreement executed between the competent authority on behalf of the BSNL and the contractor, together with the documents referred to therein including these conditions, the specifications, designs, drawings and instructions issued from time to time, by the engineer in-charge and all these documents taken together shall be deemed to form one contract and shall be complementary to one another.

l. Contractor: The contractor shall mean the individual, firm or company, approved to undertake the works and shall include the legal personal representative of such individual or the persons composing each firm or company, or the successors of such firm or company and the permitted assignees of such individual, firm or company.

m. Work: The expression “works” shall unless there be something either in the subject or context repugnant

I/727458/2024

to such construction be construed and taken to mean the works by or by virtue of the contract contracted to be executed whether temporary or permanent and whether original, altered, substituted or additional.

n. Schedule(s): Schedule(s) referred to in these conditions shall mean the relevant schedule(s) or the standard schedule of rates mentioned in the document.

o. Site: The site shall mean the land / or other places on, into or through which work is to be executed under the contract or any adjacent land, path or street through which, the work is to be executed under the contract or any adjacent land, path or street which may be allotted or used for the purpose of carrying out the contract.

p. Normal time or stipulated time: Normal time or stipulated time means time specified in the work order to complete the work.

q. Extension of Time: Extension of Time means the time granted by the BSNL to complete the work beyond the normal time or stipulated time. The EOT may be with/without Liquidated damages as may be decided by the competent authority.

r. Date of Commencement of work: Date of commencement of work means the date of actual commencement of work or 7th day from the date of issue of work order, whichever is earlier.

s. Due date of completion: Due date of completion shall be the date by which the work shall be completed at site including clearance of site.

t. Duration of completion of work: The duration of completion of work or completion time shall be time specified in the work order plus extension of time granted, if any.

u. Excepted risk: Excepted risk are risks due to war (whether declared or not), invasion, act of foreign enemies, hostilities, civil war, rebellion, revolution, insurrection, military or usurped power, any acts of Government damages from aircraft, acts of God, such as earthquake, lightning and unprecedented floods and other causes over which, the contractor has no control and the same having been accepted as such, by the Accepting Authority or causes solely due to use or occupation by the government of the part of the work, in respect of which a certificate of completion has been issued.

v. Extra work: as used herein any work or compliance with any requirements, other than a change, which is not expressly or impliedly contemplated by the contract documents, and which is necessary to be performed for the proper completion of the contracted work. For the purpose of clarifications, it is declared that, any work or operation which shall be necessarily incidental to the proper performance of any item of work or part thereof shall be deemed to have been by implication provided for in the relevant item of work or part thereof and shall not constitute extra work.

2. ELIGIBILITY OF BIDDERS:-

(i) The invitation of bids is open to all bidders as per the eligibility mentioned in NIT of this tender document.

(ii) The experience certificate for carrying out the works and amounts received should be in the prescribed pro-forma and the certificate should be under the signature of officer responsible for maintaining the contractor's ledger e.g. AGM/AO (Cash)/DDO or equivalent officer of the concerned PSU i.e. BSNL/ MTNL/ TCIL/ ITI/ Rites/ HCL/ PGCIL/ Rail Tel/ any other Govt. (Central/ State) undertaking/any other TSP/ISP, as the case may be. In case of any other TSP/ISP the date of Experience certificate should not be older than 3 months from the date of this NIT.

B. Of late big Govt. contracts are being carried out by the Public Sector Undertakings mentioned herein through a chain of contractors. In such case, the experience certificate, if issued, in favor of a contractor, in the chain, by such PSUs in the prescribed format shall be acceptable.

3. BID DOCUMENT:

The construction work to be carried out, goods required, bidding procedures and contract terms are

I/727458/2024

prescribed in the Bid Documents. The Bid Document include:

Part-A (Qualifying Bid):

Notice Inviting Tender
 Bid form
 Tenderer's Profile
 Instruction to Bidders
 General (commercial) conditions of the contract
 E-tendering Instructions to Bidders
 Special Conditions of Contract
 Important Instructions
 Scope of Work and jurisdiction of the contract
 Material Security Bond Form
 Bid Security/EMD
 PBG Format
 OF Cable Construction Specifications
 Proforma of Agreement
 Standard Schedule of Rates for carrying out the OF Cable Construction work issued by BSNL for the area of work.
 Engineering Instructions on Under Ground Optical Fibre Cable Laying Works (Section-XIII)
 Annexure-A Pro-forma of No Near Relative Certificate.
 Annexure-B Pro- forma of Experience Certificate.
 Annexure-C Declaration about Genuineness of Documents/Certificates
 Schedule of quantities stipulated under this tender and rates (Section XIX)

Part-B (Financial Bid)

Schedule for Quoting the Rates.(Section-XX)

3.2 The Bidder is expected to examine all instructions, forms, terms & conditions and the specifications in the bid documents. Failure to furnish all information required as per the Bid Documents or submission of bids not substantially responsive to the Bid Documents in every respect will be at the bidder's risk and shall result in rejection of the bid.

4. QUERIES ON BID DOCUMENT:

A prospective bidder, requiring any clarification of the Bid Documents shall notify the tender issuing authority in writing at the e-mail id indicated in the NIT for Bids. It may be appreciated that such communications is preferably done through e-mail only as any other mode of communications may result in delay for which BSNL shall not be responsible. The tender issuing authority shall respond in writing, to the same e-mail id, to any request for clarification of the Bid Documents, **which it receives within 7 days of publication of tender document.** Copies of such queries (without identifying the source) and the clarifications, if any, by the tender issuing authority shall be placed on e-tendering web-site in form of Addendum/Corrigendum and all such clarifications issued by the tender issuing authority will form part of the bid document.

5. AMENDMENT OF BID DOCUMENT:

At any time, prior to the date for submission of bids, the tender issuing authority may, for any reason whether suo moto or in response to a clarification requested by a prospective Bidder, modify the bid

I/727458/2024

documents by amendments. **Queries/clarifications sought up to four days prior to date of bid submission** shall be entertained. Any query/clarification sought less than fourteen days prior to bid opening date shall not be considered for reply/clarification. The amendments shall be notified in writing to such prospective bidders who seek clarifications on their mail id, besides uploading the same on e-tendering e tender portal. In order to afford prospective bidders reasonable time to take the amendments into account in preparing their bids, the tender issuing authority may, at its discretion, extend the deadline for the submission/ opening of bids suitably. All the amendments/ corrigendum /addenda/ extension of date(s) shall be published only on e-tendering website i.e. <https://etenders.gov.in/eprocure/app>. Therefore, the prospective bidders are advised to visit the website regularly.

C. PREPARATION OF BIDS

6. **Cost of Bidding:**

The bidder shall bear all costs associated with the preparation and submission of the bid through e- tendering. The BSNL, will in no case, be responsible or liable for these costs, regardless of the conduct or outcome of the bidding process.

7. **DOCUMENTS ESTABLISHING BIDDER'S ELIGIBILITY AND QUALIFICATION:**

The bidder shall submit the following documents online on the e-tender portal (along with the Qualifying Bid) for establishing the bidder's eligibility which are mandatory:

List of Documents in the 'Technical Bid Folder' to be uploaded on e-tendering portal
1. Scanned copy of the duly filled and signed Bid Form, Section-II of the tender document.
2. Scanned copy of the duly filled and signed Tenderer's Profile, Section-III of the tender document.
3. Scanned Copy of receipt / Demand Draft /Bankers Cheque/BG proof for on line payment of requisite value towards the price of tender document as per NIT.
4. Scanned Copy of receipt / Demand Draft / Bankers Cheque/BG proof for on line payment of requisite value for the Bid Security/EMD as per NIT.
5. Scanned copy of PAN card
6. Scanned copy of the valid EPF Registration Certificate.
7. Scanned copy of the valid ESI Registration Certificate.
8. Scanned copy of the valid GSTIN Registration Certificate.
9. Scanned copy of Solvency certificate from the banker of the tenderer: <i>For works costing up to Rs. 20 lakhs-solvency certificate should be of Rs. 5 lakhs; For works costing more than 20 lakhs-solvency certificate should be of Rs. 10 lakhs. The solvency certificate shall not be older than 3 months from the date of issue of NIT.(or) last three years audited financial statements duly certified by CA should be submitted and last three financial years cumulative turnover must be greater than equal to Total estimated cost of Tender.</i>

I/727458/2024

10. Scanned copy of the Experience Certificate(s) as per NIT in the prescribed pro-forma(Annexure-B).
11. Scanned copy of the documents, as applicable, in support of registration of the Company/Firm/Proprietorship: <ul style="list-style-type: none"> ➤ The registration of the firm, authenticated copy of partnership deed in cases of partnership firm. ➤ Attested copy of Articles of Association duly registered with Registrar of Company affairs, in case of Limited/Pvt. Limited Company. ➤ Duly executed Affidavit, stating that tenderer is the sole proprietor of the firm or any document issued by the taxation authorities stating that tenderer is the sole proprietor of the firm, in case of proprietorship firm.
12. Scanned copy of Registered Power of Attorney (duly registered with sub registrar)/Resolution of Board of Directors, authorizing individual(s) including the person with whose DSC the tender is submitted on e-tendering portal (if and as applicable).
13. Signed tender document on each and every page without any alternation/ digitally uploaded in PDF format with digital signature of the authorized signatory on the document without any alternation
14. Scanned copy of No Near relative certificate(s) in the prescribed pro-forma as per Annexure-A.
15. Scanned copy of duly completed Declaration about Genuineness of Documents/Certificates as per Annexure-C.
16. Scanned copy of MSE certificate in case bidder is an MSE bidder
17. A self- declaration along with the evidence that the bidder is not black listed by GST/BSNL authorities and MTNL/TCIL/ITI/RITES/HCL/PGCIL/RailTel/ any other Govt(Central/State) undertaking/ any other TSP/ISP as the case may be
18. Scanned Copy of Income Tax Returns for Last 3 Years(2020-2021, 2021-2022, 2022-2023)

Note:

- a.) The successful tenderer has to submit the attested copy of the Labour License, if applicable (to be ascertained by him), within one month of signing the agreement which should remain valid through the entire period of the agreement. No work Order(s) shall be issued to the successful tenderer till he submits the attested copy of the Labour License or an affidavit that he is exempted from securing labour license.
- *The one month period can be extended further by one month/specified duration subject to genuine and special reason submitted by the contractor with proof requesting for additional one month.*
- b) Tender document(s), duly filled in and signed by tenderer or his authorized representative along with seal on each page. All corrections and overwriting must be initialed with date by the tenderer or his authorized representative.
- c) The self-attested copy of required experience certificate issued by officer maintaining the payment ledger of the contractors.
- d) A mandatory undertaking from MSE bidders regarding declaration of UAM number on CPPP.
- Self-attested copy of all above mentioned documents are required to be uploaded along with the bid otherwise bid will be liable to be rejected.

Bank Account Details:Customer Name : **Accounts Officer (Cash) BSNL**

I/727458/2024

Account Number : **39219700053 IFSC Code: SBIN0003723**

Name of the Bank: State Bank of India Address of the Bank: STATE BANK OF INDIA, MACHAVARAM BRANCH, BESIDE BSNL BHAWAN, CHUTTU GUNTA, VIJAYAWADA-520004

8. BID SECURITY(EMD):

8.1 The bidder shall furnish, as part of his bid, a bid security (EMD) for an amount as mentioned in NIT. No interest shall be paid by the BSNL on the bid security for any period, whatsoever.

8.2 The bid security is required to protect the BSNL against the risk of bidders conduct, which would warrant the security's forfeiture, pursuant to para 8.7.

8.3 Bid Security shall be paid on or after the date of NIT in the form of Demand Draft/ Banker's Cheque/Bank Guarantee issued by a Nationalized/ Scheduled Bank, drawn in favour of **AO(CASH) , O/o CGMT , BSNL , Vijayawada**. Original DD of Bid Security shall be attached as part of document under technical bid para 7(4). in Physical Form.

However bidder shall submit bid declaration in the prescribed proforma as given in Section 6(E)below:

6 (E)–Declaration for BID SECURITY

I, /M/s ----- hereby declare that I participated in BSNL tender **NIT No APCO-23/11(13)/26/2024-MM AND IT DATED 23/08/2024** The bid security is not submitted by me / us as per the Ministry of Finance letter no. F.9/4/2020-PPD dated 12.11.2020 and BSNL CO letter no. BSNL CO-MMT/12(15)/1/2020 -MMT dated 05.12.2020. In case I become successful bidder, I abide that in case of withdrawal / modification of bids during the period of validity etc. and in case not abide the said tender terms and conditions, I will be suspended / debarred / banned for the period of One year from participating in tenders of BSNL.

Place:

Date:

Signature of Bidder

8.4 Scanned copy of the same DD in the favour of **AO(CASH) , O/o CGMT , BSNL , Vijayawada** shall be uploaded online while bidding.

8.5 Deleted

Note: The MSE bidders are exempted from payment of bid security:

- A proof regarding valid registration with body specified by Ministry of Micro, Small & Medium Enterprise for tendered items will have to be attached along with the bid.
- The enlistment certificate issued by MSME should be valid on the date of opening of tender.

I/727458/2024

- c) MSE unit is required to submit its monthly delivery schedule.
- d) If a vendor registered with body specified by Ministry of Micro, Small & Medium Enterprise claiming concessional benefits (Exemption from Tender cost and EMD) is awarded work by BSNL and subsequently fails to obey any of the contractual obligations, he will be debarred from any further work/contract by BSNL for one year from the issue of such order.
- e) MSE (Micro and small enterprises) bidder should declare UAM number on CPPP portal. The bidders who also fail to submit UAM number shall not be able to avail the benefits (Exemption from Tender cost and EMD) available to MSEs as contained in Public procurement policy for MSEs order, 2012 issued by Ministry of MSME. A mandatory undertaking from MSME bidders regarding declaration of UAM number on CPPP to be obtained.

8.6 A bid not secured in accordance with para 8.1 & 8.3 shall be rejected by the BSNL as non-responsive.

8.7 The bid security of the unsuccessful bidder will be refunded as promptly as possible after finalization of the contract but not later than 30 days after the expiry of the period of bid validity prescribed by the BSNL.

The bid security shall be forfeited:

8.7.1 If a bidder withdraws his bid during the period of bid validity specified in the bid document or

8.7.2 If the bidder makes any modifications in the terms and conditions of the tender before acceptance of the tender, which are not acceptable to the BSNL or

8.7.3 In case of a successful bidder, if the bidder fails:

- to sign the agreement in accordance with Section XI, or
- to furnish Material Security in accordance with clause 5 (i) of Section V.
- to observe material terms and conditions stipulated in the tender document including mandatory/ statutory/legal requirements eg. Labour, Taxation laws etc.

8.8 The successful bidder's bid security will be refunded after signing of agreement with the approved bidder.

9. **BID PRICES:**

9.1 The bidder shall give the total composite price inclusive of all levies and taxes, packing, forwarding, freight and insurance in case of materials to be supplied and inclusive of all taxes and levies but exclusive of Goods and service tax in case of works to be executed. Goods and Service tax shall be paid extra, if applicable. The contractor shall be responsible for loading/unloading and transporting the materials, to be supplied by the BSNL from any BSNL store / Telecom factory to the work site. The charges on this account shall be regulated as per the rates in Standard Schedule of Rates (SOR). The offer shall be firm in Indian Rupees.

9.2 Prices shall be quoted by the bidder as percentage below / above / at par the standard schedule of rates in the schedule of quoting rates (Financial Bid). Prices quoted at any other place shall not be considered. Quoted rates shall be inclusive of all charges and levies but exclusive of Goods and Service Tax(GST) which shall be paid extra as applicable.

9.3 The price quoted by the bidder shall remain fixed during the entire period of contract and shall not be subject to variation on any account. A bid submitted with an adjustable price quotation will be treated as non-responsive and rejected.

I/727458/2024

9.4 Discount, if any, offered by the bidders shall not be considered unless they are specifically indicated in the schedule of quoting rates (Financial Bid). Bidders desiring to offer discount shall therefore modify their offers suitably while quoting.

9.5 The estimated “cost of work per meter” is computed for the work put to tender based on surveyed quantities and prevailing SOR as mentioned in Section –XIX. The bidders are supposed to ascertain the soil strata existing in the area of the contract and quote his rates keeping in view his own ascertainment. The bidder should note that the approved percentage shall be loaded on to the estimated cost of work per meter as mentioned above to indicate the approved rate per meter. The final rate arrived post execution against this contract by and large will be within this approved rate per meter.

9.6 The rates for other Allied works/Overhead Laying are Prefixed as per SOR.

10 PERIOD OF VALIDITY OF BIDS:

Bid shall remain valid for 180 days from date of opening of the bid (Qualifying Bid). **A Bid valid for a shorter period shall be rejected by BSNL as non-responsive.**

In exceptional circumstances, the tendering authority may request the consent of the bidder for an extension to the period of bid validity for a period of up to 30 days. The request and the response there to shall be made in writing. The bid security provided under clause 8 shall also be suitably extended. The bidder may refuse the request without forfeiting its bid security. A bidder accepting the request and granting extension will not be permitted to modify its bid.

11 SIGNING OF BID:

11.1 The bidder shall prepare, as a part of his bid, the bid documents (in original) duly signed on each and every page, establishing the conformity of his bid to the bid documents of all the works to be executed by the bidder under the contract.

11.2 The bid shall contain no inter-lineation, erasures or overwriting except as necessary to correct errors made by the bidder in which case such corrections shall be signed with date by the person or persons signing the bid.

11.3 Power of Attorney:

- (a) The power of attorney **in original**, in case, person other than the sole proprietor/ authorized signatory has signed the tender document, shall be on a non-judicial stamp paper of Rs. 50/- in case same has been executed in between blood relations and in other cases, it should be on a non-judicial stamp paper of Rs.100/- and should be attested by the Notary Public or same should be registered before the sub registrar. The power of attorney in original should be submitted.
- (b) The power of Attorney in original is executed by a person who has been authorized by the Board of Directors of the bidder in this regard, on behalf of the company/ institution/ Body corporate.
- (c) In case of the bidder being a partnership firm, the said Power of Attorney should be executed by all the partner(s) in favour of the said Attorney.
- (d) Attestation of the specimen signature of such authorized signatory of the bid by the Company's/Firm's bankers shall be furnished. Name, designation, phone number, mobile number, email address and postal address of the authorized signatory shall be provided.
- (e) In case the representative of bidder company who uploads the document on e-tender portal using his Digital Signature Certificate (DSC) is different from the authorised signatory for the bid (Power of Attorney holder) then the representative who uploads the document on e-tender portal using DSC issued in his name shall also be made as one of the power of attorney holder by the bidder company, in addition to the authorised

1/727458/2024

signatory for the bid.

D. SUBMISSION OF BIDS

12 Method of Preparation & Submission of Bids in e-Tendering System:

12.1 Bid should be submitted in the following manner:

12.1.1 Documents to be submitted-

All the documents in **Qualifying Bid –Part-A** as mentioned in clause 7 of this section and **Financial Bid-Part-B** as mentioned in clause 3 of this section, are to be uploaded in the e tender portal including Bid security declaration, proof of deposit of Bid security/EMD, Cost of Tender document which maybe deposited by way of RTGS/NEFT/DD/Banker Cheque /Bank Guarantee. In that case original DD has to be dropped in the tender box. Later the L-1 bidder has to submit all the original hard copies of the entire tender document and attested copies (wherever applicable) uploaded by him whenever he has been called for in the office for submission, failing which tender will be cancelled.

The envelope must be super scribed as below and shall be dropped in the tender box.-

‘Envelope for BID security, Tender cost & Authorization’

NIT No : APCO-23/11(13)/26/2024-MM AND IT DATED 23/08/2024

“E-Tender document for -----
-----”

Section no: _____

To
AGM (Tenders)
O/o CGMT,VJ

From
Name of the place

- (i) Original Demand Draft(DD)/Banker Cheque/Bank Guarantee and Proof of payment if paid through NEFT/RTGS– drawn in favor of **Accounts Officer (Cash)** O/o CGMT, BSNL BHAVAN, Vijayawada, payable at Vijayawada , issued by any scheduled bank towards the payment/ of Bid Security/EMD.
- (ii) Original Demand Draft(DD)/ Banker Cheque and Proof of payment if paid through NEFT/RTGS – drawn in favor of Accounts Officer (Cash) O/o CGMT,BSNL BHAVAN, Vijayawada, payable at Vijayawada, issued by any scheduled bank towards the payment of Price of Bid Document.
- (iii) Original Power of attorney for authorisation to sign and upload the bid.
- (iv) Valid MSE Certificate/Udyam Registration Certificate broadly covering the tendered Equipment/services, for claiming exemption of Tender fee/Bid Security.

Note: Please note that the submission of above documents in original in **sealed envelope should be dropped in tender box at our office address on or before the tender**

1/727458/2024

bid closing time. If the technical envelope is not received within the stipulated time ie. bid submission end time, the tender bid (if already scanned copies uploaded) shall be rejected. These document should be part of Off -Line submission.

All the above documents should be self-attested by the tender signing person.

12.1.2 Submission of Bids on e-tendering website-

The bidder shall upload his bid for this tender in two separate folders marked as 'Qualifying_Bid', and 'Financial_Bid'. The bid folders shall contain the documents as given below-

- a) **'Qualifying_Bid' folder** –The scanned documents in electronic form as per clause 7 of Section IV must be uploaded in this folder.
- b) **'Financial Bid' folder-** The Rates duly quoted in the prescribed format as per Section-XX, Schedule for Quoting the Rates.

12.2 The tenders which are not submitted in above mentioned manner shall be summarily rejected.

12.3 The tenderer will be bound by all terms, conditions & specifications as detailed in the tender documents.

Any tender with conditions other than those specified in the tender document is liable to be summarily rejected. No modification by the contractor in any of the conditions will be permitted.

13 SUBMISSION OF e-BIDS:

13.1 E-Tenders should be submitted strictly as per the procedure mentioned in clause 12 above. The tenderer is to ensure the delivery of the physical envelope at the correct address and submission of the Qualifying Bid and Financial Bid online as mentioned above. The BSNL shall not be held responsible for delivery of bid to the wrong address or wrong submission/non-submission of the bid online.

13.2 If tender opening day is declared as holiday by the government then the bids technical or financial will be opened on the next working day. The Time & Venue will remain unchanged.

13.3 LATE BIDS:

Tenders shall not be accepted online after the specified date and time of closing of the tender. It is the sole responsibility of the tenderer that he should ensure timely online submission of tender and in the manner as prescribed on the e-tendering website.

The time settings fixed in the server side & displayed at the top of the e-tendering site, will be valid for all actions of requesting, bid submission, bid opening etc., in the e-tender system. The bidders should follow this time during bid submission.

13.4. Post Bid submission: No documents post bid submission shall be entertained/taken. Any deficient bid in this regard may be summarily rejected. However, any clarifications on the submitted bid documents may be sought to examine and evaluate the bid, if required for the sake of clarity.

14. MODIFICATIONS AND WITHDRAWAL OF BIDS :

14.1. The bidder may modify or withdraw his bid before the due date and time of submission in the manner as prescribed on the e-tendering website.

I/727458/2024

14.2. No bid can be modified subsequent to the deadline for submission of bids.

E. BID OPENING AND EVALUATION:

15. Opening of bids by the BSNL:

TOC shall open and download the Qualifying Bids online after the due date and time by logging into the e-tender portal. The bidders whose Physical Envelopes marked as '**Bid Security & Authorization Envelope**' are not received in time (any date on or before bid submission end date) or the documents do not meet the preliminary requirement of eligibility, the tender bid if already opened on basis of scanned copies uploaded, shall be rejected.

The Qualifying Bids downloaded shall be evaluated by the designated TEC and the result of evaluation after approval by the competent authority shall be uploaded on the E-tender portal for information of all concerned clearly mentioning the qualified bidders and not qualified bidders (with reasons for non-qualification after approval by the competent authority shall be uploaded on the E-tender portal for information of all concerned clearly mentioning the qualified bidders and not qualified bidders (with reasons for non-qualification)

The **FINANCIAL BID** shall be opened in the following manner:

- i). The folder marked "**Financial_Bid**", will be opened only for those bidders who have been found eligible after evaluation of Qualifying Bids.
- ii). The date and time of opening of Financial Bid shall be notified on e-tendering portal for information of all the bidders.
- iii). After opening the "Financial Bid" the TOC shall prepare the report containing the bidder's name, bid prices, modifications, etc.
- iv). In case there is a discrepancy in figures and words in the quote, the same shall be announced in the bid opening, but the quoted rates in words shall prevail.

16. CLARIFICATION OF BIDS BY THE BSNL:

To assist in examination, evaluation and comparison of bids, the BSNL may, at its discretion ask the bidder for clarification of its bid. The request for its clarification and its response shall be in writing. However, no post bid clarification at the initiative of the bidder shall be entertained.

17. VERIFICATION OF BIDS BY THE BSNL

If any of the documents, required to be submitted along with the technical bid is found wanting, the offer is liable to be rejected at that stage. However, the BSNL at its discretion may call for any clarification regarding the document within a stipulated time period. In case of non-compliance to such queries, the bid will be outrightly rejected without entertaining further correspondence in this regard.

18. PRELIMINARY EVALUATION:

BSNL shall evaluate the bids to determine whether they are complete, whether any computational errors have been made, whether required sureties have been furnished, whether the documents have been properly signed and whether the bids are generally in order.

Prior to the detailed evaluation, the BSNL will determine the substantial responsiveness of each bid to the bid document. For purpose of these clauses a substantially responsive bid is one which conforms to all the

I/727458/2024

terms and conditions of the bid documents without deviations. The BSNL may waive any minor infirmity or non-conformity or irregularity in a bid which does not constitute a material deviation, provided such waiver does not prejudice or affect the relative ranking of the bidder.

19. EVALUATION AND COMPARISON OF SUBSTANTIALLY RESPONSIVE BIDS:

The BSNL shall evaluate in detail and compare the bids previously determined to be substantially responsive. The evaluation and comparison of responsive bids shall be on the offered and indicated in schedule of quoting rates of the bid documents. Bidder quoting **section wise** the lowest rates will be L-1 for that **section** of the tender. It is the composite price quoted for that section of the tender.

20. CONTACTING THE BSNL:

20.1. No bidder shall try to influence the BSNL on any matter relating to its bid, from the time of bid opening till the time the contract is awarded.

20.2. Any effort by the bidder to modify his bid or influence the BSNL in the BSNL's bid evaluation, bid comparison or the contract award decisions shall result in the rejection of the bid.

21 AWARD OF CONTRACT & DISTRIBUTION OF WORK:

21.1 The BSNL shall consider award of the contract **section wise** only with L-1 bidder quote whose offers have been found technically, commercially and financially acceptable. The L-1 bidder is one who quotes the lowest rate.

21.2 If there are more than two tenderers at the same rates, the tenderer having highest experience in 7 or 5 years period category (as the case may be) shall precede to the one having lower experience while deciding ranking for considering for the award of work. The final ranking, L-1, L-2, L-3 etc. shall be worked out using the highest experience irrespective of criteria of 7 or 5 years period category.

21.3 If L-1 bidder refuses to accept the offer, BSNL will go for Re-tender.

The following are the Terms & Conditions:

- The Rate quoted shall be section wise to all the sections in the NIT.
- After tendering there should be post-tender negotiations with L-1, except in certain exceptional situations. That situations and circumstances duly recorded and documented with necessary justification.
- In case of retendering due to unreasonableness of the quoted rates, as the requirements are urgent and a re-tender for the entire requirement would delay the execution of the work, negotiation will be carried out with L-1 bidder for the RKM which can be executed and the balance to be done through re-tender, following the normal conditions.
- Finalization of the number of bidders for awarding the work order is under the discretion of the BSNL authorities based on the quantum of the RKM in the NIT.

22. BSNL'S RIGHT TO VARY QUANTUM OF WORK:

The quantity stipulated in the tender are estimated and the BSNL reserves the right to vary the value of works to the extent of -25% to + 25% of contract value during contract period at the same rates and terms & conditions with prior approval of the tender approving authority.

However, **in exceptional circumstances only**, due to change in scope of work or otherwise, any variation in the value of work may be permitted up to 50% of contract value with prior approval of the next higher authority after recording adequate reasons and justification for the same.

23. Liability :

BSNL will not be liable to the contractor for any losses or damages, costs, charges which the contractor may in any way sustain/suffer due to non-issue of work order/delay in making store available or delay in receipt of permission from road authorities/local bodies/forest department.

24. BSNL'S RIGHT TO ACCEPT ANY BID AND TO REJECT ANY OR ALL BIDS :

The BSNL reserves the right to accept or reject any bid and to annul the bidding process and reject all bids, at any time prior to award of contract without assigning any reason whatsoever and without thereby incurring any liability to the affected bidder or bidders on the grounds for the BSNL's action.

25. ISSUE OF LETTER OF INTENT:

- 25.1. The issue of letter of intent shall constitute the intention of the BSNL to enter into the contract with the bidder. Letter of intent will be issued as offer to the successful bidder.
- 25.2. The bidder shall within 14 days of issue of letter of intent, give his acceptance along with Performance security in conformity with clause 5(ii) of Section V, provided with the bid documents. However, Tender Issuing Authority reserves the right to extend the time limit if the reasons on which extension is sought are deemed fit.

26. SIGNING OF AGREEMENT:

- 26.1. Once the tender is approved by the competent authority and Letter of Intent (LoI) is issued, the contractor shall deposit the Performance Bank Guaranty (PBG) and Material Security in the form of Bank Guaranty (BG) within fourteen days. The Bid Security deposited along with the tender shall be refunded to the bidder after signing of the agreement.
- 26.2. An agreement shall be signed after submission of PBG and material Security.

27. ANNULMENT OF AWARD:

Failure of the successful bidder to comply with the requirement of clause 25 of section IV shall constitute sufficient ground for the annulment of the award and forfeiture of the bid security, in which event; the BSNL may make the award to any other bidder at the discretion of the BSNL or call for new bids

28. Security Clause

Mandatory Licensing requirements with regards to security related concerns issued by Government of India from time to time shall be strictly followed.

29. Reservation/ Procurement from MSE Units

The guidelines / instructions issued vide D.O. No. 21(1)-2011-M.A. April 25th 2012 from Micro, Small & Medium Enterprise & subsequent clarifications/guidelines thereafter shall be followed. (MSEs registered with District industries Centre (DICs)/ Khadi village Indu. Commission (KVIC)/Khadi village Indu. Board KVIB)/ NSIC/directorate of handicrafts & handloom or any other body specified by Ministry of MSME.)

----- END OF SECTION-IV -----

SECTION V

GENERAL (COMMERCIAL) CONDITIONS OF THE CONTRACT**1. APPLICATION:**

The General conditions shall apply in contracts made by the BSNL for the execution of Laying PLB pipe and associated works by Open Trench Method/Trenchless Technology (HDD), Underground Optical Fibre Cable Pulling/Blowing , Over Head OFC laying and splicing works

2. STANDARDS:

The works to be executed under the contract shall confirm to the standards prescribed in the OF Cable construction practices and OFC laying Engineering instructions issued by BSNL using open trenching and Trenchless Technology (HDD) methods.

3. PRICES:

Prices charged by the Contractor for the works performed under the Contract shall not be higher from the prices quoted by the Contractor in his Bid. Price once fixed will remain valid for the period of contract. Increase and decrease of taxes/duties will not affect the price except Goods and Service tax (GST) which will be paid at prevailing rate, during this period (proof of payment to the GST authority shall be submitted by the contractor on time to avail ITC by BSNL.)

4. SUBCONTRACTS:

The contractor shall not assign, sub contract or sublet the whole or any part of the works covered by the contract, under any circumstances.

5. SECURITY:**(i) Material Security:-**

a. Section wise successful tenderer including MSE bidder will have to deposit material security as mentioned in the scope of work subject to **10%** of the tender approved value (rounded to next hundred) in the form of bank guarantee, valid for the period of contract plus six months, from a scheduled bank and in the **material security bond form** provided in the bid documents **Section-X**.

Material security can also be submitted in the form of cross demand draft drawn in favor of **AO(CASH) , O/o CGMT , BSNL , Vijayawada** issued by a schedule bank and payable at **Vijayawada**. The Material security will be non-interest bearing deposit for any period whatsoever. BSNL reserves the right to increase the amount of material security based on the quantum of work/maximum store to be issued at the time of execution of the work at any point of time.

b. The contractor at any point of time will not be issued stores costing more than material security. If due to any reason, more store has to be issued to the contractor then the material security shall be correspondingly enhanced. In this regard, the decision of Concerned DE-in-charge shall be final and binding.

c. The proceeds of the material security shall be payable to the BSNL as a compensation for any loss resulting from the contractor's failure to account for the material issued to him.

d. The Material security shall be released / refunded within a month from the date of the payment of the last final bill of the work under the contract or final settlement of material account whichever is later on production of 'No Dues Certificate' from 'Engineer In Charge'.

ii) Performance security:

- a. **Section wise** successful bidder including MSE bidder shall submit an amount equivalent to **5%** of the tender approved value as security deposit by way of Performance Bank Guarantee (PBG) within 14 days from the date of issue of LOI, in favour of **AO(CASH) , O/o CGMT , BSNL , Vijayawada** from any scheduled bank in India, and valid for 30 months from the date of issue of LOI. An additional 18% amount of GST is also to be paid along with **5%** of the approved tender value (rounded to next hundred), if paid in the form of Performance Bank Guarantee (PBG).
- b. On receipt of PBG from the bidder, after confirmation of the genuineness of the PBG from the bank, the EMD, if any, received earlier, will be returned.
- c. The proceeds of the performance security shall be payable to the BSNL as compensation for any loss resulting from the contractor's failure to perform the obligations under the contract and warranty obligations.
- d. The performance security deposit shall be refunded after expiry of warranty period of last work executed provided there are no recoveries to be made arising out of poor quality of work, incomplete work and/or violation of any terms and conditions of the contract as stipulated in the biddocument.
- e. If there are recoveries to be made, Contractor shall deposit the money before the release of PBG forgetting the PBG released and in failure to do so, PBG will be forfeited and recovery to be effected from the realized PBG amount and the balance amount, if any, after adjustment of recoveries, will be refunded to the bidder.
- f. It is the responsibility of the vendor to submit the proof that he has deposited the Goods & service tax in time. Otherwise BSNL will recover from subsequent bills or PBG as the case may be.
- g. No interest will be paid to the contractor on the security deposit.

6. ISSUE OF WORK ORDERS AND TIME LIMIT:

- i). Work will be executed by way of issuing work orders. Work orders may be issued in parts for a period as specified in the work order. The work order shall be for a part of work which will have to be completed in time as specified in work order.
- ii). The work orders shall be issued by the **AGM/DE of concerned BA/OA/section or AGM(Tenders), O/o CGMT, AP Circle** after Pro-forma work order approval from Tender Approving Authority by examining the technical and planning details of the works to be executed.
- iii). The BSNL reserves the right to cancel or modify the scope of work stipulated to be carried out against the work order in the event of change of plan necessitated on account of technical reasons or in the opinion of work order issuing authority or competent authority, the contractor is not executing the work at the required pace.

7. EXTENSION OF THE TIME LIMIT:**7.1. General:**

- In each work order, the work order issuing authority shall specify the time allowed for completion of work consistent with the magnitude and urgency of work. The time allowed for carrying out the work is to be strictly observed by the contractor and shall be reckoned from seventh day from the date of issue of work order.
- In as much as "the time being deemed to be the essence of contract", throughout the stipulated period of contract, the work is to be proceeded with all due diligence on the part of the contractor.

1/727458/2024

7.2. Application for Extension of Time and Sanction of Extension of Time (EOT) :

7.2.1. There may be some hindrances, other than covered under force majeure, while execution of work and in such cases the contractor shall apply in writing to the engineer-in-charge for extension of time (EOT), on account of which, he desires such extension, on the same day of occurrence of hindrance. The Engineer-in-charge shall forward the request to the competent authority with his detailed report, within two days of receipt of request from the contractor. The competent authority is empowered to grant extension of time for completion of work on certain conditions. He shall exercise such powers, if the following conditions are satisfied.

7.2.1.1. The application contains the ground(s), which hindered the contractor in execution of work.

7.2.1.2. The Engineer-in-charge is of the opinion that the grounds shown for extension of time are reasonable.

7.2.2. The competent authority shall consider the request keeping all the facts and circumstances in view and shall grant extension of time, if in his opinion, there are reasonable and sufficient grounds for granting such extension and the reasons for delay are not ascribable to the contractor.

7.2.3. -The competent authority may also grant extension of time for completion of work in cases where reasons for delay are ascribable to the contractor, but such extension of time shall be with LD charges as per clause dealing with Liquidated damages (LD) for delays in execution of works.

7.2.4. The competent authority shall grant EOT with time period for completion of work clearly mentioned. The sanction of the competent authority of EOT shall be issued under the signature of the Engineer-in-charge.

7.2.5. If the competent authority is of the opinion that the grounds shown by the contractors are not reasonable and sufficient and declines to grant the extension of time, the contractor cannot challenge the soundness of the opinion by reference to arbitration. The decision of the competent authority on period of extension of time or refusal for extension of time shall be final and binding on the contractor.

7.3. Grant of Extension of Time without Applications:

7.3.1. There are, at times, practical difficulties like non-availability of material, delay in providing permissions/right of way etc. reasons of which are ascribable to the BSNL. In such cases, the Engineer-in-charge with the approval of competent authority to sanction EOT, may issue extension of time suo moto without waiting for contractor to make an application for EOT. Entry of hindrance shall be made in the Hindrance Register. The BSNL will, however, not be liable to the contractor for any losses or damages, costs, charges, or expenses that the contractor may in any way sustain / suffer due to delay in making the above available.

8.**8.1 A. DUCT INTEGRATION TEST AND DEROPING INCLUDES THE FOLLOWING WORKS.**

- a) Digging of Manhole and reinstatement
- b) De-roping of PLB Pipe (if existing).
- c) Fixing of couplers including cutting of PLB duct and aligning
- d) Clearing obstructions, if any, by opening Test Pits and reinstatement.

Testing the each Kilometer duct for leakages with pressure (DIT)

DIT—SPECIFICATION / TESTING THE DUCT

Purpose of duct integrity Test is to ascertain and ensure the suitability of the duct for cable installation through jetting. It is first necessary to ensure that the duct into which cable is to be installed is continuous over the length of the duct. Some reasons for lack of continuity are:

- Missing Sections of Duct
- Couplers not connected
- Over lapping of Ducts

The Air Test establishes the duct continuity. Air is introduced from one end of the duct. If air comes out from the other end of the duct, then it is established that the duct is continuous. If no air emerges, then the fault is to be identified and corrected before proceeding further. Duct overlap can lead to potentially very dangerous situations and should be corrected promptly.

Second step in the DIT Test is to establish that there is a clear passage for the cable to go through the duct. Possible reasons for lack of clear passageway are:

- Kink in the Duct
- Blockage in the Duct

These deficiencies are to be corrected before proceeding further. Kink in the duct may be caused at the duct laying stage when back filling may have been done without taking care to keep boulders out of the way and out of the trench. A fallen boulder on top of a laid duct can cause the problem. The kink may also have been caused at the de-coiling stage, when this is attempted without use of a de-coiler.

The kink in the buried duct is located through the shuttle Test. A suitable shuttle is first passed through the duct. The shuttle will get stuck at the point where the duct is either kinked or blocked. Next, a transmitter is passed through the duct. It gets stuck behind the shuttle. The path of the duct is then tracked with a receiver. As the receiver passes over the transmitter, the signal from the transmitter is heard loud and clear. In this way the transmitter, and just ahead the shuttle, and just ahead the kink are located. The spot is marked and the trench has to be dug up again. The boulder responsible for the kink should be removed. The portion of the damaged pipe is to be cut and replaced with good duct of equal length. Joint with laid duct is to be made with push-fit coupler.

Cable installation through jetting can be carried out successfully only under a pressure of 10 bar. Before cable installation is attempted, it is necessary to verify that the duct can hold this pressure. This is the major purpose of the pressure Test.

- Possible reasons for failure of DIT pressure test are: Leakage at Couplers & Puncture in Duct

Coupler leakage is caused by improper installation of coupler. A puncture in the duct can result from improper handling of the duct. A sharp-edged boulder if it comes to rest on top of the buried duct can also puncture the duct. Air leakage from the leaking coupler or the punctured duct is the tale sign of the problem which can then be rectified.

Thus, in summary, the DIT Test is conducted prior to cable installation with a view to check and if necessary rectify so it is made suitable for cable installation. The possible duct faults that may show up during the DIT Test process are:

- Missing sections of duct
- Couplers not connected
- Overlapping of Ducts
- Kink in the Duct
- Blockage in the Duct
- Leaking at Couplers
- Puncture in Duct

These faults are to be corrected before proceeding further. The DIT Test consists of the following steps:

- Air blowing purpose is to ensure that there are no discontinuities (or missing sections) in the duct
- Shuttle of a diameter 80% of the duct inside diameter and of 150 mm length is passed through the duct. Purpose is to check for bends, kinks, crush and deformity in the duct.
- Sponge of a diameter two times the duct inside diameter, and length 100 mm is blown through the duct. Purpose of passing the sponge through the duct is to clean the duct.
- Pressure test is conducted at 5 bar pressure for 30 Minutes with maximum permissible drop of 0.5 bar

Air blowing:

Air is introduced into the duct and a check is made at the end of the 2 Kms section of duct. Possibilities are:

1. Normal flow of air is perceived at the other end. So far - so good, proceed further with the DIT Test.
2. No flow of air at the other end of the duct: Trouble is indicated, Leakage at couplers, puncture in duct, missing duct, duct overlap, blockage in the duct.
3. Less than normal flow of air. Leakage at couplers, puncture in duct.

I/727458/2024

If there is no flow of air at the other end, check the pressure at the point where air is introduced into the duct. If the pressure is less than normal this would rule out blockage in the duct. It would indicate leakage from the duct or at a coupler location. Higher than normal pressure, would indicate blockage in the duct.

The problem can be localized by opening the coupler at the 1 Kms. point and introducing air once again through the duct. This will help identify whether the problem exists in the first kilometer of the duct under check or the second kilometer.

Shuttle Test:

Once the air test has been successfully concluded, a shuttle of a diameter 80% of duct inside diameter and of 150 mm length is passed through the duct. Purpose is to check for bends, kinks, crush and deformity in the duct. If the shuttle passes through successfully this confirms that the bends in the duct are gradual and there are not kinks or deformity that would hinder the progress of the cable during the installation process. The shuttle should pass through the 2 Kms. duct length in a space of three minutes.

In case there is a problem and the shuttle does not emerge from the other end of the duct even after 5 to 6 minutes, then a transmitter is to be blown through the duct to identify where the shuttle is stuck. A receiver at the 1 km point will pick up the signal from the transmitter as it goes by, and in this way it will be known that the shuttle is stuck in the second kilometer of duct. If no signal is picked up then the problem would have been localized as existing in the first kilometer, shuttle, and the kink in the duct would be identified, and the duct can be suitably rectified.

Oftentimes the shuttle gets stuck due to a minor kink, and when the transmitter is blown the shuttle and transmitter both come out the same time

Sponge Blowing:

Purpose of blowing sponge through the duct is to clean it. A sponge of a diameter twice the inside diameter of the duct, and 100 mm in length, is blown through the duct. The time required for the sponge to pass through the 2 Kms. duct length is three minutes.

Pressure Test:

The pressure test is conducted at 5 bar pressure. Over a 30 minutes period the pressure loss should not exceed 0.5 bar. Once this pressure test passed, the duct is pronounced ready and fit for cable installation.

TOP PLATES

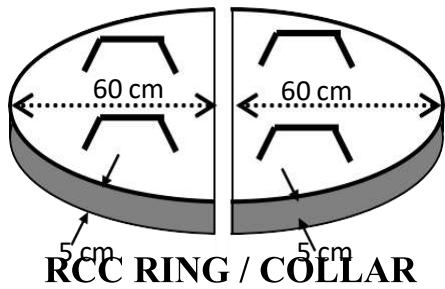

RCC RING / COLLAR

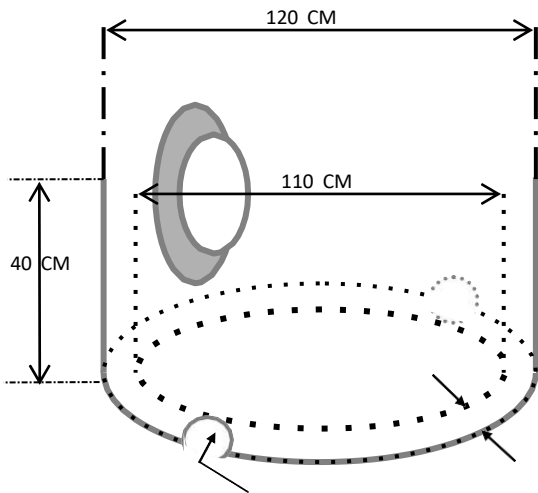

RCC RING / COLLAR :

Inner Diameter : 110

cm Outer Diameter :

120 cm

Thickness : 5 cm

Height : 40 cm

2 nos of 80 mm dia semicircular holes for cable entry diametrically opposite to each other at bottom end of the collar.

TOP PLATES:

2 nos. of semicircular plates of 120 cm dia

(60 cm radius) with two handles and 5 cm thickness.

BOTTOM PLATE:

120 cm outer dia circular single (Not two pieces) plate, 5 cm thickness

5 CM

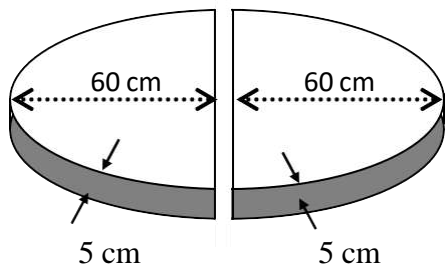

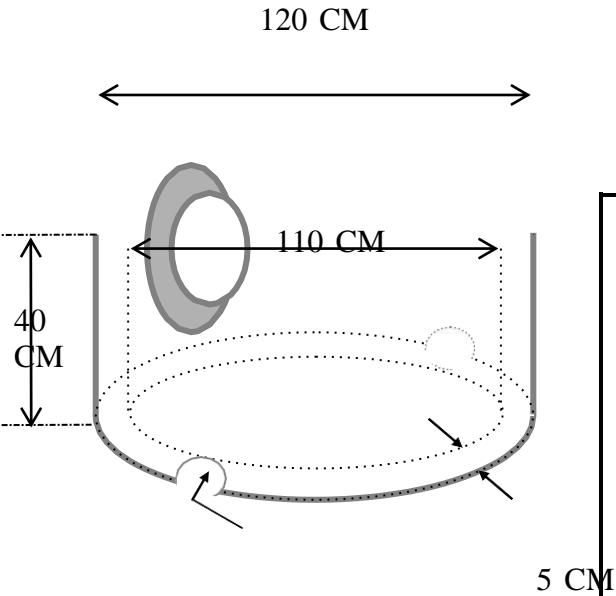

Cable entry Holes

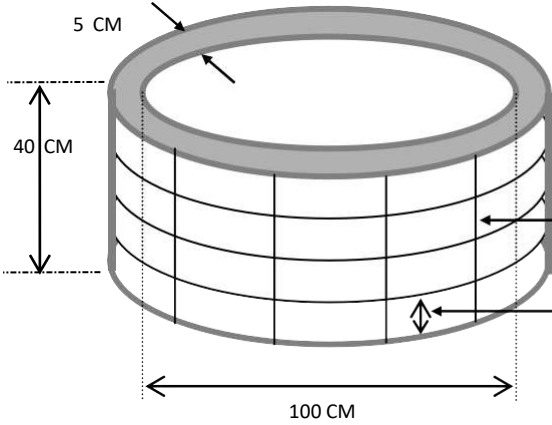

RCC JOINT PROTECTION CHAMBERS

RCC RING:

NOTE :

a) Concrete MIX : 1:2:3

Inner Diameter : 110 cm

Outer Diameter : 120 cm

Thickness : 5 cm

Height : 40 cm

2 nos of 80 mm dia semicircular holes for cable entry diametrically opposite to each other at bottom end of the collar.

Bharat Sanchar Nigam Limited

O/o The Divisional Engineer Telecom

DRG. No.

SCALE : NTS

DATE :

APPROVED BY :

Vertical Bars

Horizontal Bars

RCC RING / COLLAR

OTHER CONDITIONS :

- 1) Prepared reinforcement to be shown to the purchaser /representative of the purchaser.
- 2) Concrete MIX to be made in the presence of the Divisional Engineer.

B. CABLE BLOWING INCLUDES THE FOLLOWING WORKS.

- a) Transportation of Cable Drums/Joint Rings including loading, unloading handling and local distribution.
- b) Digging of Joint Pits and Placement of Joint Chambers and fixing of Joint Indicators.
- c) Filling Fine River sand for Joint Chambers and reinstatement.
- d) After blowing of cable, the both ends of PLB Pipe in each manhole should be sealed by hard rodent reinstatement rubber bush, to avoid entry of rodents / mud into PLB Pipe.
- e) BSNL reserves the right to order the planting and painting of the Route Indicators also on the contractor and the work is to be done at the Prefixed Rate.
- f) *Store can be lifted from the Store Godown if vis the concerned BA/OA.*

- C. **TRENCHING:** (Part in Cable Blowing): The work involves digging Manholes/Test Pits/Joint Pits as described below:-

Manhole: Size: 2 M. (Length) X 1.8 M. (Depth) in all types of Soil and reinstatement of the same to original ground level including positioning and fixing of coupler and reinstating the manhole, normally at the rate of 2 to 5 Manholes per KM.

During the excavation of Manholes on CC Roads it may be required to cut and open the CC Roads. Restoration of the CC Roads is to be carried out at the fixed rate.

- I. **TEST PITS:** Size: 1.5 M (Length) x 0.6 M (Width) x 1.7 M (Depth), if required, for clearing obstructions.

II (A). JOINT MANHOLE IN THE ROUTES:

The RCC Chambers will normally be supplied by the BSNL, (alternatively, the tenderer has to supply the same at the prefixed rates) the contractors should dig the pits in all types of soil and placing RCC Chambers, filling with river sand and reinstating with excavated earth. Joint indicators are to be fixed and painted including sign writing. Indicators will be supplied by Contractor as per the specification at pre fixed rates.

II (B). JOINT MANHOLES IN ACCESS NETWORK ROUTES:

Digging of Pits and placing of RCC Chambers will be taken up by the suppliers of chambers.

- III. REINSTATEMENT:** This involves back filling of the excavated soil and consolidating it in the trench by rammers and bringing to the original ground level in Manholes/Test Pits. At Joint Pits of long distance routes, RCC Chambers are to be placed properly over the cable coils after protecting the coil properly with split pipes. RCC chamber is to be completely filled with river sand before closing the joint chambers (Procurement of Sand and transportation to the site is to be arranged by contractor at their own cost). The pre-fabricated RCC Chambers of proper size (approximately 1.2 M Dia) is to be supplied at prefixed rate by the contractors at the store godown en-route. All the manholes are to be filled with river sand upto 4" above the pipe. The contractor should be in a position to dig at least 30 (Thirty) Nos. of Pits/Manholes per day on average.

The contractor should himself provide the necessary digging tools, capping materials,

I/727458/2024

caution boards, red lamps during night works etc. at his own cost for his workers and he should also observe all prescribed pre-cautions during this work for safety of pedestrians, vehicular traffic etc. The contractor should engage a minimum labour force of 25 people on any day. No conveyance charges for labour or transportation will be provided by the department for digging of Joint Pits/Test Pits/Manholes.

D. Manholes marked during PLB Pipe Laying shall be excavated for blowing the cables. There may be situations where additional manholes are required to be excavated, for some reasons, to facilitate smooth blowing of cable. Excavation of additional manholes will be carried out, without any extra cost. De-watering of the manholes, if required, will be carried out without any extra cost. De-watering/De-gasification of the ducts, if required, will be carried out without any extra costs.

E. The de-ropeing of existing 6 mm PP rope is required between the two consecutive manholes. This is to ensure that the PLB Pipes are cleaned for blowing the cable without exerting undue tension on the OF Cable. While cleaning, excessive pressure should not be put which may result in breaking of PLB Pipe and thus requires opening of additional manholes. However in case the cleaning rope gets stuck up, the location of clogging of pipe should be measured and located accurately. The trench at that location should be opened and the pipe should be cleaned properly or if not possible it should be changed by a clean new pipe to facilitate easy cable blowing at a later stage without any breakage. If clogging of pipe is in the location where the pipes are protected either by RCC Pipe or by concreting and the protection is broken for cleaning/changing the PLB Pipe, the protection thus removed should be brought back to normal by the contractor without any extra cost. However, PLB Pipes, RCC Pipes required for this purpose will be supplied and CC Charges will be paid by the Department.

F. CABLE BLOWING: Blowing of Optical Fibre Cable through PLB Pipe already laid andmaking coils so that the ends will be ready for splicing.

- i) The cable drums which may be of different lengths will be made over to the contractor at the nearest store godowns. The accessories like Jack & Axle etc. shall be arranged by the contractor. The contractor has to make arrangement for moving the labour force to the site as and when required. No departmental conveyance would be made available.
- ii) The recovered material like rope, and caps and empty cable drums should be returned to the Site Engineer at the Store Godown, after cable blowing operations, failing which an amount of Rs. 250/- per each empty drum and as per the value of other stores will recovered from the bill (s).
- iii) If any damages occurred to the cable in the blowing operations, the contractor has to make good of the loss to the department.
- iv) The contractor has to quote the rate for blowing/de-blowing per meter basis. While quoting the rate, the contractor has to assess the charges that he may have to incur over the entire operation involved in the work. No extra payment will be made whatsoever for any additional work the contractor work the contractor has to perform while cable blowing/de- blowing is done.
- v) The cable blowing work is to be done as and when required by the Divisional Engineer, BSNL or his authorized representative.
- vi) The contractor has to be in a position to blow at least 2 to 4 Kms. per day.
- vii) Required cable drums will be issued on receipt from the Division Store Godown at Industrial Estate OR any other nearby BSNL Store location as per store availability.

MEASUREMENT, INSPECTION, TESTING AND ACCEPTANCE TESTING:

A. Open Trenching:

Measurement:

1.1 The measurement books are to be maintained by the officer-in-charge of the work or his immediate engineering subordinate not below the rank of Junior Telecom Officer. The entry shall be made in ink. No entry shall be erased. If a mistake is made, it should be corrected by crossing out the incorrect words or figures and inserting the corrections, the corrections thus made shall be initialed & dated by the officer concerned.

1.2 Responsibility of taking and recording measurements:

The measurement of various items of work shall be taken and recorded in the measurement book issued with each work order. The measurement shall be taken and recorded by an officer not below the rank of Junior Telecom Officer, supervising the work.

The Junior Telecom Officer/Sub Divisional Engineer, directly responsible for supervision of work, shall be responsible for accuracy of 100%/50% of measurements respectively. The Divisional Engineer shall be responsible for conducting test check of 20% of measurements. In case where SDE directly supervises the work, he shall be responsible for accuracy of 100% of measurements.

1.3 **Method of recording of nomenclature of items:** Complete nomenclature of items, as given in the agreement need not be reproduced in the measurement book for recording the measurements but corresponding Item Code as provided, shall be used.

1.4 **Method of measurements:** The measurements of the work shall be done activity wise as and when the item of work is ready for measurement. The methods of measurement of various items are enumerated as under:

• **Measurement of depth of trenches:**

The cable routes of one work order shall be divided into a number of segments each of maximum 200 meters length bounded by identifiable landmarks at both the ends of the segments. If landmarks are not available, length of segment may be maintained at 200 meters. The measurement of depth shall be recorded at each point of measurement (POM) in the measurement book in meters in the multiples of 5 cms. For example 97 cms will be recorded as 95 cms and 103 cms as 105 cms. The points of measurements shall be at a distance of 10 meters starting from 0 (zero) Meter. For example, if the length of segment is 75 meters, the POMs shall be at 0M, 10 M, 20 M, 30 M, 40M, 50M, 60 M, 70M. The last POM shall be at 75th M to be recorded against Residual POM. The efforts required to excavate trenches is not proportionate especially with reference to depth. Therefore, normally the workers tend to dig shallow trenches. As standard depth of the trench is important for future life and protection of cables, this tendency has to be discouraged. In order to encourage the contractor to achieve best possible depth in the face of site constraints, the following scale of payment shall be applied for digging trenches of lesser depths, subject to condition that relaxation has been granted by the competent authority for lesser depths.

Table-1 For Normal & Hard soil for all areas AP Circle

Depth between	Reduction in rate
< 165 Cms to ≥ 150 Cms.	Pro rata basis
< 150 Cms to ≥ 130 Cms.	12.5 % of approved rates
< 130 Cms to ≥ 105 Cms.	25 % of approved rates
Below 105 Cms	40 % of approved rates

Table-2 For soft/hard rock for all areas of AP Circle.

Depth Between	Reduction in rate
< 135 Cms to > 125 Cms.	5% of the approved rate.
<125 Cms to > 105 Cms	15% of the approved rate.
Below 105 Cms.	40% of the approved rate.

Table-3 For Hilly Terrain for all areas of AP Circle

Depth between	Reduction in rate
< 90 Cms to \geq 80 Cms.	5 % of the approved rate
< 80 Cms to \geq 65 Cms.	12.5 % of approved rates
< 65 Cms to \geq 50 Cms.	25 % of approved rates
Below 50 Cms	40 % of approved rates

The payment for sub normal length should be calculated using the following formula:

$$P = (100 - ROR) \times RA \times D / (100 \times ND)$$

P = Payment for one meter

ROR = Reduction in rate in % as given above

RA = Approved rate of trenching per meter

D = Actual depth in Cms.

ND = Nominal depth of trench 165/135/90cms for which the tender has been floated.

• **Measurement of Lengths and profiles of strata and protection:**

The measurements of length of trenches are on running meter basis, irrespective of type of soil encountered while digging.

The type of protection provided (item code-wise) in a segment shall be recorded in the measurement book in the sheet provided for this purpose.

• **Measurement of length of cable:** The length of cables laid in trenches, through pipes and through ducts shall be measured by use of RODO Meter/Measuring Tape. The length should be cross verified with the marking of lengths on the cables. The lengths shall be recorded in sheet provided in the measurement book.

• **Measurement of other items:** The measurement/numerical details of other items shall be recorded in the sheets provided for respective items viz.

- Digging of joint pit and preparation of joint chamber along with its type i.e. Brick chamber or Pre Cast RCC type.
- Fixing, Painting and sign writing of route/joint indicators.
- Termination of Cable in equipment room and no. of joints.

1.5 The contractor shall sign all the measurement recorded in the measurement book. This will be considered as an acceptance by the contractor, of measurements recorded in the MB. In case contractor fails to attend at the measurements or fails to countersign or to record the difference within a week, then in any such events the measurements taken by Engineer-in-charge or by the subordinate as the case may be shall be final and binding on the contractor and the contractor shall have no right to dispute the same.

1.6 The Divisional Engineer before passing the bill for sections covered by each set of measurement may carry out test check by re-opening trench at as many locations as necessary, as specified in document 'procedures for underground cable construction' and bills will be passed only when he is personally satisfied of the correctness of entries in the "measurement Book" and also when he is satisfied of other aspects of the work as per the terms of the contract. The contractor shall provide the necessary assistance of labour for re-opening of trench for test check by the Divisional Engineer. Separate payment shall not be made to the contractor for excavation of such test checks, however such test pits shall not be more than 10% of the cable laying work.

1.7 Measurement of the work of cable pulling through pipe/duct will be taken equal to the length of the pipe / duct through which the cable has been pulled and not the total length of the cable pulled through pipe/duct.

B. Guidelines for Depth AT of Horizontal Directional Drilling

Brief Description of the work: A high capacity drilling machine is used to drill the earth in almost horizontal manner and hence the name of the technology. Two manholes of 2 Mt X 2Mt X 2 Mt pits are taken at the places marked by the site engineer. The distance between these manholes can vary from a minimum of 40 metres to 250 metres.

I/727458/2024

The drilling is done from Entry pit towards the Exit pit. At the Exit pit the PLB pipes are attached to the drill rods and the pipes are pulled back towards the Entry pit.

In general RCC manholes are constructed at the Entry pit and Exit pit after the HDD work is completed.

HDD work along with manholes:

The location of manholes shall not only depend on the capacity of the machine but also on the roads. The man holes where the drilling commences is called the Entry Pit. The second manhole is called as Exit pit.

Normally if the HDD machine is kept near the Entry pit and the drilling is carried out, then the depth at which the Machine enters the earth shall not be less than 1.2 Mt. As per the T&D standard any pipe laying less than 1.2 Mt requires additional protection. In order to achieve higher depth at the Entry pit the HDD machine is kept at around 6 to 8 meters away from the Entry pit. A separate pit called as pilot entry pit is dug up at 4 to 6mtr away from the Entry pit.

Wherever the roads are not in straight line, the span length reduces between the Entry and Exit pit. In general in overlay access works, the manholes are constructed at every 200 Mtrs approximately. The PLB pipes are coupled using the HDPE couplers.

The HDD machine drills the earth using 3 meter length rods. These rods jointed to each other by welding. In the beginning of the first rod contains the drill bit and an electronic beacon house. While the underground drilling work is in progress the drill bit position can be monitored from the surface of the earth using a tracker. The depth and the direction of the bit are monitored from the tracker. This is due to beacon house located in the drill bit.

In the onward drilling from the entry pit to Exit pit normally a lesser diameter (4 inch diameter) drill bit is used. After the drill bit reaches the Exit pit, the drill bit and the beacon house are removed from the first rod. A higher diameter drill bit called, Back reamer is attached to the first rod. The pipes are attached to the reamer and the rods are pulled back. Thus in the return path the tracker cannot detect the depth and direction of the reamer. Hence depth of the pipes can be monitored during the drilling from Entry pit towards Exit pit only.

In general the HDD technology is used in the cities where open trenching is not permitted. These roads are covered thick BT surface. For verifying the depth the test pits cannot be taken in the middle of the road. The second difficulty arises due to the depth of the pipes, which are at about 3 meters below the surface. It is very difficult to manually open a test pit to verify the depth. Hence carrying out the depth AT after the entire work is completed is not possible as is done in the usual depth check. Hence the Depth AT for the HDD work shall be done in real time.

The following tests and suggestions are recommended for the PLB pipes being laid using the HDD technology. Apart from the depth check, the pipes continuity check is also recommended especially for the ACCESS network jobs where multiple pipes are laid.

Standard Tests:

1. Online depth and offset check of the PLB pipes. The depth can be monitored from the tracker. The accuracy of the tracker may be verified by site-in charge before the work is commenced. The depth of the pipe should be more than 2.0 Mtrs.
2. The depth of the pipe may be recorded at the Entry pit and the Exit pit of the spans under test. The depth at both the places should be more than 1.2 Mtrs.
3. The depth at least two coupling points are to be verified in 1 KM. The depth should be more than 1.2 Mtrs.
4. The offset of the pipe may be recorded both from the center of the road and also from the edge of the road wherever the compound wall exists (City Areas).
5. The depths of the pipes at a minimum of six continuous rods are to be verified by the T&D wing. The depth should be more than 2 Mtrs beyond 10 meters from the trailing edge of Entry pit.
6. The colors of the pipes to be recorded in case of multiple PLB laying. Different types of colored

1/727458/2024

pipes are to be used.

Protection: It is recommended that the regular depth protection standards may be applied for HDD works also.

Depth Relaxation: The depth relaxation is required at some situations. In general when HDD is used only for crossing the roads and short spans of 15 to 25 Mtrs length, due to the paucity of the road margin and due to the site conditions, the depth of 2.0 Mtrs may not be achieved. The depth also cannot be achieved at places where very old underground concrete structures, water and drainage pipes exist. It is recommended that the depth relaxation may be given by the competent authority.

Sl.No.	Depth measured at 10 mtrs from the trailing edge of the Entry Pit	Recommending Authority	Relaxing Authority
1	> or = 1.65 Mtr to 2.0 mtr	SDE in charge	DET In charge
2	> or = 1.5Mtr to 1.65 mtr	DET in charge	DGM in-charge

Note:- For depth more than 165 cms rates for horizontal drilling will remain same. In case of depths being less than 1.65 Mtrs up to 1.5 mtrs, the payment of horizontal drilling will be made on prorata basis. It is hereby recommended that no pipe shall be laid by HDD method for depths less than 1.5Mtrs. Hence no protection is required for the Pipes.

1.8 Inspection and Quality Control:

1.8.1 The Quality of Works: The importance of quality of Optical Fibre Cable Construction works especially laying of multiple PLB pipes/coils using open trenching and Trenchless Technology (HDD) method cannot be over-emphasized. The quality and availability of long distance media, efficiency of the reliable media connectivity to exchanges and success of new concept of overlay access network depends upon quality of laying of Optical Fibre Cable. Further, the OF cables are vulnerable to damages due to work of other agencies.

1.8.2 It is imperative that the contractor(s) is/are fully conversant with the construction practices especially laying multiple pipes by trenchless technology using HDD machine and shall be fully equipped to carry out the work in accordance with the specifications.

The contractors are expected and bound to ensure quality in construction works in accordance with specifications laid down. The contractor shall engage adequate and experienced supervisors to ensure that works are carried out as per specifications and with due diligence and in a professional manner. The contractors shall satisfy himself/themselves that the work conforms to the quality specifications before offering the same to A.T. Wing for Acceptance and Testing.

1.8.3 An assessment of extent of interest shown by the contractors in executing the works with requisite quality shall be recorded and used in evaluating the Contractors' Performance Rating (CPR).

1.8.4 In addition to Acceptance Testing being carried out by A.T. Wing and supervision by Construction Officers, all works at all times shall be open to inspection of the department. The contractors shall be bound, if called upon to do so, to offer the works for inspection without any extra payment.

1.8.5 **Site Order Book:** The site order book is one of the primary records to be maintained by the JTO/SDE supervising the work during the course of execution of works. The noting made by officers as well as contractors, will form as basis for operation of many contractual clauses. The contractor shall remove all the defects pointed out by the department in the Site order book. The contractor or their authorized representatives shall also be at liberty to note their difficulties etc. in these books. The site order books shall invariably be consulted at the time of making final payments to the contractor.

1.9 Testing and Acceptance Testing:

1.9.1 The work shall be deemed to have been completed only after the same has been accepted

I/727458/2024

by the A.T. Officer. The contractor shall make test pits at the locations desired by A.T. Officer for conducting test checks without any extra payment. The contractor shall restore the pits after test measurements to its original shape. The contractor shall be responsible to provide test/measurement tools and testers for conducting various tests for the AT of Underground OFC Layingworks as per the T&D Guidelines.

1.9.2 Scope of Acceptance and Testing: The purpose of acceptance and testing is to verify integrity of measurement and quality of work done. The A.T. Officer shall not be responsible for recording of measurements for the purpose of billing and contractual obligations. However, if the measurements taking by A.T. officer are found to be lesser than the measurements recorded by the officer responsible for recording the measurements, the measurement taken by A.T. officer shall prevail without prejudice to any punitive action against the contractor as per provisions of the contract and the officer recording the measurements. The contractor shall be obligated to remove defects/deficiencies pointed out by the A.T. officer without any additional cost to the department.

1.9.3 Offering the work for acceptance and testing: The Sub Divisional Engineer responsible for construction, after having satisfied himself of completion of work ready for A.T. shall offer the work to A.T. Officer for conducting Acceptance and Testing. The work shall be offered for A.T. as soon as part of work is complete in all respects. The work against any work order can be offered for A.T. in a number of stages.

1.9.4 The contractor shall provide labor, if demanded by the A/T officer for digging of test pits and other necessary infrastructure for carrying out the A/T work. No extra payment will be made for the digging of test pit)

9 WARRANTY:

- 9.1. The contractor shall warrant that the material supplied for the work shall be new and free from all defects and faults in material, workmanship and manufacture and shall be of the highest grade and consistent with the established and generally accepted standards for materials of the type ordered and shall perform in full conformity with the specifications and drawings. The contractor shall be responsible for any defects that may develop under the conditions provided by the contract and under proper use, arising from faulty materials, design or workmanship such as corrosion of the equipment, inadequate quantity of materials etc. and shall remedy such defects at his own cost when called upon to do so by the BSNL who shall state in writing in what respect the stores are faulty. This warranty shall survive inspection or payment for, and acceptance of goods, but shall expire except in respect of complaints notified prior to such date, **twelve months after the acceptance testing.**
- 9.2. If it becomes necessary for the contractor to replace or renew any defective portion/portions of the material under this clause, the provisions of the clause shall apply to the portion / portions material so replaced or renewed or until the end of the above mentioned **period of twelve months**, whichever may be later. If any defect is not remedied within a reasonable time, as prescribed by the BSNL, the BSNL may proceed to do the work at the contractor's risk and costs, but without prejudice to any other rights which the BSNL may have against the contractor in respect of such defects.
- 9.3. **The Cable joint shall be guaranteed for a period of ONE year from the date of closing of joint.** In case of failure of the joint due to poor workmanship i.e. failure of joint without external damage, within the stipulated period of guarantee the contractor shall repair the joint(s) at his own cost within 24 hours of informing him, **failing which the BSNL may carry out the repairs and penalty equivalent to five times of the approved rate of the jointing work plus the cost of materials used shall be recovered from the contractor from his pending bill/SD or any amount due to him without prejudice to any other action as per terms and conditions of the tender.** The cost of joining kit, supplied by the BSNL, so used to revive the joint shall be deducted from the final bill of the contract or pending for payment or from security if all bills have been settled.

1/727458/2024

9.4. Replacement under warranty clause shall be made by the contractor free of all charges at site including freight, insurance, cost of works and other incidental charges.

10. **AUDIT AND TECHNICAL EXAMINATION:**

10.1. BSNL shall have the right to cause an audit and technical examination of the work and the final bills of the contractor including all supporting vouchers, abstract etc. to be made after payment of the final bill and if as a result of such audit and technical examination any sum is found to have been overpaid in respect of any work done by the contractor under the contract or any work claimed by him to have been done by him under the contract and found not to have been executed, the contractor shall be liable to refund the amount of over payment and it shall be lawful for BSNL to recover the same from him in the manner prescribed in clause with the heading payment of bills (same chapter), or in any other manner legally permissible and if it is found that the contractor was paid less than what was due to him under payment shall be duly paid by BSNL to the contractor.

10.2. Provided that BSNL shall be entitled to recover any sum overpaid, nor the contractor shall be entitled to payment of any sum paid short where such payment have been agreed upon between the Divisional Engineer or his subordinate officer on one hand and the contractor on the other under any term of the contract permitting payment for work after assessment by the **Competent Authority** or his subordinate officer.

10.3. Any sum of money due and payable to the contractor (including security deposit returnable to him) under this contract may be appropriated by the BSNL for the payment of a sum of money arising out or under any other contract made by the contractor with the BSNL.

11. **PAYMENT TERMS:**

11.1. **Procedure for Preparation and settlement of bills :**

All items of work involved in the work order shall be completed in all respects before preparing the bills for the work against the work order. The procedure for preparation of final bills is enumerated as under.

11.1.1. **Procedure for preparation, processing and payment of bill: +**

As the work of a route is being executed through work orders for section/segment of the route, there is no provision for running bill. The payment will be released after acceptance and testing of the work ordered against the said work order. The contractor shall prepare the final bill in triplicate after completion of the entire work entrusted against work order & acceptance and testing of all the works and submit the one copy to SDE in-charge of work for making the suitable entries in SAP MIGO/SES for proposing **LD/any other deductions, if applicable, as per the Penalty clauses of 9.3, 12 & 13 of Section V, clause 4, 6.3, 12, 20 & 24 of Section VIII and Section XVIII** i/r/o any delay/deficit services/works or any shortage of inventory & 2 bill copies to Claims section, O/o CGMT, CO VJ for processing of the bill within 30 days of acceptance and testing for payment. The final bill shall be prepared for all the measurements of all items involved in execution of complete work order. The contractor shall prepare the final bill containing the following details:

- The bill for all the quantities as per Measurements at the approved rates.
- Adjustment of performance security deposit and statutory taxes already recovered.
- Store reconciliation statement furnishing account of stores received against the work order and returned to the designated Store go -down as surplus with requisite verifications from store in-charge/SDE in-charge of work.
- Letters of grant of E.O.T(s), if work could not be completed within stipulated time.
- Six sets of bound documentation.
- Copy of the Wage Register, Attendance Register, Monthly EPF & ESI Deposit Challan have to be

I/727458/2024

submitted by the contractor along with the bills.

11.1.2.(1) The SDE in-charge of work shall scrutinize the final bill against the works entrusted and accord necessary certificates stating that the work has been executed satisfactorily in accordance with specifications and terms and conditions of the contract. The SDE shall verify the quantities of items of work with reference to measurements recorded in the measurement book (and also A/T reports in case of any deviations noted by A/T office).

The SDE in-charge of work shall submit the final bills, along with other documents mentioned above, with the documents as mentioned here under to the Divisional Engineer, in-charge of work.

- Bill prepared by the contractor. **Invoice should be GST compliant**
- Material reconciliation statement.
- Measurement Book.
- A/T Certificates.
- The site order Book.
- The hindrances register.
- Details of recoveries/penalties for delays, damages to Departmental/Third party properties as per provisions of the contract. In case no recovery is to be made, NIL report needs to be submitted.
- Details of empty cable drums cost which needs to be recovered from the bill.

11.1.2.(2).The Divisional Engineer shall exercise the prescribed checks on the bills and accord necessary certificates on the bills. The Divisional Engineer shall retain the copy of the bill along with photocopies of other documents not available in his estimate file and bill, measurement book and other documents submitted by SDE. The required documents should be attached while completing SAP MIGO/SES entries for further processing of SAP MIRO by Claims section, O/o CGMT, CO VJ for final payment.

11.1.2.(3). Claims section will process the MIRO document based on inputs provided by consignee as well as **any LD/other deductions, if applicable, as per the Penalty clauses of 9.3, 12 & 13 of Section V, clause 4, 6.3, 12, 20 & 24 of Section VIII and Section XVIII.** Claims section, O/o CGMT, CO VJ will scrutinize the bills to recover all the liabilities of the contractor and statutory taxes. The bill shall be passed by the officer competent to pass the final bill. **GST shall also be applicable for any deductions or penalties imposed by BSNL.**

11.2. Procedure for payment for substandard works:

11.2.1. The contractors are required to execute all works satisfactorily and in accordance with the specifications. If certain items of work are executed with unsound, imperfect or unskilled workmanship or with materials of any inferior description or that any materials or articles provided by him for execution of work are unsound or of a quality inferior to that contracted for or otherwise, not in accordance with the contract (referred to as substandard work hereinafter), the Divisional Engineer in-charge shall make a demand in writing specifying the work, materials or articles about which there is a complaint.

11.2.2. **Timely action by Site-In-charge: Timely reporting and action, to a great extent, can prevent occurrence of substandard work, which will be difficult or impossible to rectify later on. It is incumbent on the part of Site-In-charge to point out the defects in work in time during progress of the work.** The Junior Telecom Officer/Sub Divisional Engineer responsible for execution and supervision of work shall without any loss of time submit a report of occurrence of any substandard work to the Divisional Engineer in-charge besides making an entry in the site order book. A notice in respect of defective work shall be given to the contractor by Divisional Engineer in-charge in writing during the progress of work asking the contractor to rectify/replace/remove the substandard item of work and also define time period within which such rectification/removal/replacement has to be done. After expiry of the notice period, if the contractor fails to rectify/replace/remove the substandard items, the defects shall be got rectified/replaced/removed departmentally or through some other agency at the risk and cost of

I/727458/2024

the contractor.

- 11.2.3. Non-reporting of the substandard work in time on the part of Site In charge (s) shall not in any way entitle the contractor to claim that the defects were not pointed out during execution and as such the contractor cannot be absolved of the substandard work and associated liabilities.
- 11.2.4. **Authority and Procedure to accept substandard work and payment thereof:** There may be certain items of work pointed out as substandard which may be difficult to rectify and in the opinion of the Tender Issuing Authority, the items in question will not materially deteriorate the quality of service provided by the construction, Tender Issuing Authority shall appoint committee to work out the reduced rates payable to the contractor for such substandard work. The committee shall constitute one Divisional Engineer other than the one who is directly in-charge of Cable Construction involving substandard items of work, as Chairman and one SDE and an Accounts Officer as members. The committee shall take into account the approximate cost of material/work pointed out as substandard and recommend the rates payable for substandard work which shall not exceed 60% of the approved rates of the item in question.
- 11.2.5. Record of substandard work: The items adjudged as substandard shall be entered into the measurement book with red ink.
- 11.3. **No claim for delayed payment due to dispute etc:** No claim for interest or damage will be entertained or be payable by the BSNL in respect of any amount or balance which may be lying with the BSNL owing to any dispute, difference or misunderstanding between the parties or in respect of any delay or omission on the part of the Engineer in charge in making intermediate or final payments or in any other respect whatsoever.

12. **DISPOSAL OF EMPTY CABLE DRUMS:**

- 12.1. The contractor shall be responsible to dispose off the empty cable drums after laying of the cable. The competent authority taking into account the prevailing market rates has fixed the cost of Optical Fibre cable drums. The cost of empty cable drums shall be deducted from the bill for the work on which the cable along with the drum has been issued or any other amount due to the contractor or from security deposit.
- 12.2. Rates fixed for Optical Fibre cable drums are given in Tender Document (Qualifying Bid). The rates are fixed and there is no percentage above or below applicable on these rates.
- 12.3. The contractor shall be responsible for the accounting of the cable drums issued and shall mention the number of cable drums in the bill so that the amount is deducted from the bills due.
- 12.4. The contractor shall not be allowed to dump the empty cable drums in Govt., public place, which may cause inconvenience to Govt. /Public. If the contractor does not dispose off the empty cable drums within 3 days of becoming empty, the BSNL is at liberty to dispose off the drum in any manner deemed fit and also recover the amount fixed in this contract for empty cable drums along with the transportation charges to be decided by the **Competent Authority** from the bill / security deposit / any other amount due to the contractor.

13. **LIQUIDATED DAMAGES/PENALTY CLAUSE:**

13.1. Liquidated Damages clause for Delays in the contractor's performance:

13.1.1. The time allowed for completion of the work as per work order shall be strictly adhered by the contractor and shall be deemed to be the most important aspect of the contract on the part of the contractor and shall be reckoned from Seventh day from issue of work order by the BSNL. The work shall, throughout the stipulated period of contract, be proceeded with all due diligence to achieve the desired progress uniformly, and the contractor shall pay as Penalty for delay in execution of the work @ 0.5% for each week of delay or part thereof, for a period up to ten weeks and thereafter @ 0.7 % for each week of delay or part thereof for another ten weeks subject to a maximum of 12 % of the cost of the work allotted as per the **work order**.

13.1.2. On any date the penalty payable as above, reaches 12 (twelve) percent of the cost of the work,

1/727458/2024

the contractor should proceed with the work further only on getting a written instructions from the Divisional Engineer that, he is allowed to proceed further with the work. It will be in the discretion of the Divisional Engineer to allow the contractor to continue with the work on the basis of any written agreement reached between the contractor and the Divisional Engineer. One of the conditions of such agreement may be a stipulation for the contractor to agree for realization of penalty for delay at a higher rate as may be agreed between Divisional Engineer and contractor.

13.1.3. The days on which work is not done due to reasons beyond the control of contractor, such as natural calamities, law & order situation etc., will not be accounted for in imposing the Penalty.

13.1.4. Penalty for delay in completion of the work shall be recoverable from the bills of the contractor and/or by adjustment from the security deposit or from the bills of any other contract. However, adjustment from security deposit will be made only when the contract has been terminated or at the time of final settlement of bills on completion of work.

13.1.5. In case of slow progress of the work in a section which has been awarded to a particular contractor, if the public interest does not permit extension of time limit for completion of the work, then Tender Issuing Authority will have the full right to order that the scope of the contract may be restricted to such fraction of the work and get the balance work executed at the risk and cost of the contractor. The details are given in Rescission of the contract clause of the bid document. All such payments shall be recovered from the contractor's pending bills or security deposit.

13.1.6. The Tender Issuing Authority reserves the right to cancel the contract and forfeit the security deposit if the contractor fails to commence the work within 7 days after issue of the work order or as the time permitted by the competent authority.

13.2. Penalty for causing inconvenience to the Public:

13.2.1. To ensure progress during the execution of work and to cause minimum inconvenience to the public, the contractor shall not dig a trench of more than 200 meters at a stretch in a route at a time. He shall cause to lay cable and close such trenches expeditiously. Under any circumstances a stretch of trench of maximum 200 meters shall not be kept open for more than 2 days in case of cable laying by digging paved surfaces. In the event of contractor falling to comply with, these conditions, a penalty of recovery up to Rs.300/-per day the trench is kept open beyond the time limit allowed may be imposed by the BSNL. This penalty will be in addition to that payable for delay or slow work.

13.2.2. The contractor shall not be allowed to dump the empty cable drums/waste materials in Govt./public place, which may cause inconvenience to Govt./Public. If the contractor does not dispose off the empty cable drums/waste materials within 3 days of becoming empty, the BSNL is at liberty to dispose off the drum in any manner deemed fit also recover the amount fixed in this contract for empty cable drums/waste materials from the bill/security deposit/ along with the costs incurred by the BSNL in disposing off such materials. In addition, BSNL may also levy a penalty up to Rupees One thousand only for each such default.

13.3. Penalty for cutting / damaging the old cable:

13.3.1.1 Penalty for cutting/damaging the old cable:

During excavation of trench utmost care is to be taken by the contractor, so that the existing underground cables are not damaged or cut. In-case any damage/cut is done to the existing cables, a penalty as per the schedule given below will be charged from the contractor or the amount will be deducted from his final bill.

Size of existing UG cable Cut /damaged	Account of penalty per cut/damage
Upto 100 pairs cable	Rs 3000.00 (Three thousand)
Above 100 pairs cable & up to 400 pairs	Rs 5000.00 (Five thousand)
Above 400 pairs	Rs 10000.00 (Ten thousand)

For OF Cable Penalty for cutting/damaging will be as below:

1/727458/2024

Type of cable Cut /damaged	Charges per fault for penalty and compensation
OF Cable of any size	Rs 50000.00 (Fifty thousand)

Besides the above penalty, the contractor shall carry out such repairs for restoration of the damaged cable free of charge. The cost of jointing kit, shall also be borne by the contractor. If contractor fails to repair the damage, the cost of repair (including cost of Labour + Jointing kit) shall be recovered from the contractor.

13.3.2. Penalty to damage stores/materials supplied by the BSNL while laying:

The contractor while taking delivery of materials supplied by the BSNL at the designated place shall thoroughly inspect all items before taking them over. In case of execution of the work, if any material is found damaged/working unsatisfactorily, then a penalty equivalent to the cost of material + 10% as penalty shall be recovered from the contractor's payments/securities.

However, contractor will not be penalized for any defect in workmanship of the materials, which shall be taken up separately with the supplier of the stores.

13.3.3. Penalty to damage the underground installation of other agencies:

While trenching, the contractor should not cause damage to any underground installations belonging to other agencies and any damage caused should be made good at his own cost and expenses.

13.3.4. Penalty for achieving lower depth : In no case the statutory depth of boring should be (i) less than 2 mtr from the road / ground surface and (ii) less than 1.65 mtrs at the pits. In order to encourage the contractor to achieve required depth in the face of site constraints, the following payment schedule with penalty are to be adhered to for boring at lesser depths subject to condition that relaxation has been granted by the competent authority for lesser depths.

(i) For ground surfaces (other than pits) :

Actual Micro-tunneling (HDD) depth between	Penalty
< 2 Mtr. to > 1.50 Mtr	10% of approved rate
<1.5 Mtr	No payment. To be treated as non-standard work

(ii) For pits :

Actual Micro-tunneling (HDD) depth between	Penalty
< 1.65 Mtr. to > 1.50 Mtr	10% of approved rate
<1.5 Mtr	No payment. To be treated as non-standard work.

14 Rescission / Termination of Contract:

14.1. Circumstances for rescission of contract: Under the following conditions the Tender Issuing Authority may rescind the contract:

- (i) If the contractor commits breach of any item of terms and conditions of the contract.
- (ii) If the contractor suspends or abandons the execution of work and the engineer in-charge of the work comes to conclusion that work could not be completed by due date for completion or the contractor had already failed to complete the work by that date.
- (iii) If the contractor had been given by the officer-in-charge of work a notice in writing to rectify/replace any defective work and he/she fails to comply with the requirement within the specified period.

Upon rescission of the contract, the security deposit of the contractor shall be liable to be forfeited and shall be absolutely at the disposal of the BSNL as under:

14.2. Measurement of works executed since the date of last measurement and up to the date of

I/727458/2024

rescission of contract shall be taken in the presence of the contractor or his authorized representative who shall sign the same in the MB. If the contractor or his authorized representative do not turn up for joint measurement, the measurement shall be taken by the officer authorized for this purpose after expiry of due date given for joint measurement. The measurement taken by the officer so authorized shall be final and no further request for joint measurement shall be entertained.

14.2.1.1. The unused material (Supplied by the BSNL) available at site, shall be transported back by the BSNL to the Telecom Store at the risk and cost of the contractor. If any such material is found damaged/lost then the penalty shall also be recovered from the contractor as per conditions in tender documents/bid.

14.2.2. The un-executed work shall be got executed through the qualified bidder from amongst the bidders, who participated in the bidding process, by giving them offers in their order of ranking (L2,L3...) at L1 quoted rates. If the work was awarded on single tender basis then the BSNL shall get the unexecuted work completed through any other contractor approved in the area of Tender Issuing Authority at the approved rates of that particular section or to execute the work departmentally, as is convenient or expedient to the BSNL at the risk and cost of the contractor. In such a event no compensation shall be payable by the BSNL to the contractor towards any inconvenience/loss that he may be subjected to as a result of such an action by the BSNL. In this regard the decision of **Tender issuing Authority** shall be final and binding. In all these cases, expenses which may be incurred in excess of the sum which would have been paid to the original contractor if the whole work had been executed by him shall be borne and paid by the original contractor and shall be deducted from any money due to him by the BSNL under the contract or his any other account whatsoever anywhere in the BSNL or from a security deposit.

14.2.3. The certificate of the Divisional Engineer in-charge of work as to the value of work done shall be final and conclusive against the contractor, provided always that action shall only be taken after giving notice in writing to the contractor.

14.3. Termination for Insolvency:

14.3.1. The BSNL may at any time terminate the Contract by giving written notice to the Contractor, without compensation to contractor, if the contractor becomes bankrupt or otherwise insolvent as declared by the competent court provided that such termination will not prejudice or affect any right or action or remedy which has accrued or will accrue thereafter to the BSNL.

14.3.2. Optional Termination by BSNL (other than due default of the contractor):

14.3.3. The BSNL may, at any time, at its option cancel and terminate this contract by written notice to the contractor, in which event the contractor shall be entitled to payment for the work done upto the time of such cancellation.

14.3.4. In the event of the termination of the contract, the contractor shall forthwith clear the site of all the contractor's materials, machinery and equipment and hand over possession of the work/operations concerned to the BSNL or as the BSNL may direct. The BSNL may, at its option, cancel or omit the execution of one or more items of work under this contract or any part of such items without any compensation, whatsoever, to the contractor.

14.3.5. Issuance of Notice:

14.3.6. The Divisional Engineer in-charge of work shall issue show cause notice giving details of lapses, violation of terms and conditions of the contract, wrongful delays or suspension of work or slow progress to the contractor directing the contractor to take corrective action. A definite time schedule for corrective action shall be mentioned in the show cause notice. If the contractor fails to take corrective action within the stipulated time frame, the Divisional Engineer in-charge shall submit a draft of final notice along with a detailed report to the competent authority who had accepted the contract.

14.3.7. The **final notice for rescission of contract** to the contractor shall expressly state the precise date and time from which the rescission would become effective. The following safe guards shall be taken while issuing the final notice.

1/727458/2024

- a) During the period of service of notice and its effectiveness, the contractor should not be allowed to remove from the site any material/equipment belonging to the BSNL.
- b) The contractor shall give in writing the tools and plants he would like to take away/remove from the site. Such of the materials as belong to him and which may not be required for future execution of balance work may be allowed by the Divisional Engineer in-charge of work to be removed with proper records.
- c) No new construction beneficial to the contractor shall be allowed.
- d) Adequate BSNL security arrangement in replacement of the contractor watch and ward shall be made forthwith. Expenses on this account are recoverable from the security deposit or any amount due to the contractor.

15. INDEMNITIES :

15.1. The contractor shall at all times hold the BSNL harmless and indemnify BSNL from and against all action, suits, proceedings, works, cost, damages, charges claim and demands of every nature and descriptions, brought or procured against the BSNL, its officers and employees and forthwith upon demand and without protest or demur to pay to the BSNL any and all losses and damages and cost (inclusive between attorney and client) and all costs incurred in endorsing this or any other indemnity or security which the BSNL may now or at any time have relative to the work or the contractors obligation or in protecting or endorsing its right in any suit on other legal proceeding, charges and expense and liabilities resulting from or incidental or in connection with injury, damages of the contractor or damage to property resulting from or arising out of or in any way connected with or incidental to the operations caused by the contract documents. In addition, the contractor shall reimburse the BSNL or pay to the BSNL forthwith on demand without protest or demur all cost, charges and expenses and losses and damages otherwise incurred by it in consequences of any claim, damages and actions which may be brought against the BSNL arising out of or incidental to or in connection with the operation covered by the contractor.

15.2. The contractor shall at his own cost at the BSNL's request defend any suit or other proceeding asserting a claim covered by this indemnity, but shall not settle, compound or compromise any suitor other finding without first consulting the BSNL.

16.FORCE MAJEURE:

16.1. If any time, during the continuance of this contract, the performance in whole or in part by either party or any obligation under this contract shall be prevented or delayed by reason of any war, or hostility, acts of the public enemy, civil commotion sabotage, fires, floods, explosions, epidemics, quarantine restrictions, strikes, lockouts or act of God (Herein after referred to as events) provided notice of happenings of any such eventuality is given by either party to the other within 21 days from the date of occurrence thereof, neither party shall by reason of such event be entitled to terminate this contract nor shall either party have any such claim for damages against the other in respect of such non-performance and work under the contract shall be resumed as soon as practicable after such event may come to an end or cease to exist, and the decision of the BSNL as to whether the work has been so resumed or not shall be final and conclusive, provided further that if the performance, in whole or part of any obligation under this contract is prevented or delayed by reason of any such event for a period exceeding 60 days, either party may, at his option terminate the contract.

16.2. Provided also that if the contract is terminated under this clause, the BSNL shall be at liberty to take over from the contractor at a price to be fixed by the BSNL, which shall be final, all unused, undamaged and acceptable materials, bought out components and stores in the course of execution of the contract, in possession of the contractor at the time of such termination of such portions thereof as the BSNL may deem fit excepting such materials, bought out components and stores as the contractor may with the concurrence of the BSNL select to retain.

17. ARBITRATION:**I. ARBITRATION (Applicable in case of supply orders/Contracts with firms, other than Public Sector Enterprise) (Not applicable in cases valuing less than Rs. 5 lakhs)**

Except as otherwise provided elsewhere in the contract, if any dispute, difference, question or disagreement arises between the parties hereto or their respective representatives or assignees, in connection with construction, meaning, operation, effect, interpretation of the contract or breach thereof which parties unable to settle mutually, the same shall be referred to Arbitration as provided hereunder:

(1) A party wishing to commence arbitration proceeding shall revoke Arbitration Clause by giving 60 days' notice to the designated officer of the other party. The notice invoking arbitration shall specify all the points of disputes with details of the amount claimed to be referred to arbitration at the time of invocation of arbitration and not thereafter. If the claim is in foreign currency, the claimant shall indicate its value in Indian Rupee for the purpose of constitution of the arbitral tribunal.

(2) The number of the arbitrators and the appointing authority will be as under:

Claim amount (excluding claim for counter claim,if any)	Number of arbitrator	Appointing Authority
Above Rs. 5 lakhs to Rs.5 crores	Sole Arbitrator to be appointed from a panel of Arbitrators of BSNL.	BSNL (Note: BSNL will forward a list containing names of three empaneled arbitrators to the other party for selecting one from the list who will be appointed as sole arbitrator by BSNL)
Above Rs. 5 crores	3 Arbitrators	One arbitrator by each party and the 3 rd arbitrator, who shall be the presiding arbitrator, by the two arbitrators. BSNL will appoint its arbitrator from its panel.

(3) Neither party shall appoint its serving employee as arbitrator.

4. If any of the Arbitrators so appointed dies, resigns, becomes incapacitated or withdraws for any reason from the proceedings, it shall be lawful for the concerned party/arbitrators to appoint another person in his place in the same manner as aforesaid. Such person shall proceed with the reference from the stage where his predecessor had left it both parties consent for the same; otherwise, he shall proceed de novo.

5. Parties agree that neither party shall be entitled for any pre-reference or pendent-lite interest on its claims. Parties agree that any claim for such interest made by any party shall be void.

6. Unless otherwise decided by the parties, Fast Track procedure as prescribed in Section 29 B of the Arbitration Conciliation Act, 1996 and amended in 2015 for resolution of all disputes shall be followed, where the claim amount is up to Rs. 5 crores.

[29B. Fast track procedure – (1) Notwithstanding anything contained in this Act, the parties to an arbitration agreement, may, at any stage either before or at the time of appointment of the arbitral tribunal, agree in writing to have their dispute resolved by fast track procedure specified in sub-section (3).

(2) *The parties to the arbitration agreement, while agreeing for resolution of dispute by fast track*

I/727458/2024

procedure, may agree that the arbitral tribunal shall consist of a sole arbitrator who shall be chosen by the parties.

(3) The arbitral tribunal shall follow the following procedure while conducting arbitration proceedings under sub-section (1):-

- (a) The arbitral tribunal shall decide the dispute on the basis of written pleadings, documents and submissions filed by the parties without oral hearing;*
- (b) The arbitral tribunal shall have power to call for any further information or clarification from the parties in addition to the pleadings and documents filed by them;*
- (c) An oral hearing may be held only, if, all the parties make a request or if the arbitral tribunal considers it necessary to have oral hearing for clarifying certain issues;*
- (d) The arbitral tribunal may dispense with any technical formalities, if an oral hearing is held, and adopt such procedure as deemed appropriate for expeditious disposal of the case.*

(4) The award under this section shall be made within a period of six months from the date the arbitral tribunal enters upon the reference.

(5) If the award is not made within the period specified in sub-section (4), the provisions of sub-sections (3) to (9) of Section 29 A shall apply to the proceedings.

(6) The fees payable to the arbitrator and the manner of payment of the fees shall be such as may be agreed between the arbitrator and the parties.]

7. The arbitral tribunal shall make and publish the award within time stipulated as under:

Amount of Claims and Counter Claims	Period for making and publishing of the award (counted from the date the arbitral tribunal enters upon the reference)
Up to Rs. 5 crores	Within 6 months (Fast Track procedure)
Above Rs. 5 crores	Within 12 months

However, the above time limit can be extended by the Arbitrator for reasons to be recorded in writing with the consent of parties and in terms of provisions of the Act.

8. In case of arbitral tribunal of 3 arbitrators, each party shall be responsible to make arrangements for the travel and stay, etc. of the arbitrator appointed by it. Claimant shall also be responsible for making arrangements for travel/stay arrangements for the Presiding Arbitrator and the expenses incurred shall be shared equally by the parties. In case of sole arbitrator, BSNL shall make all necessary arrangements for his travel/stay and the expenses incurred shall be shared equally by the parties.

9. The Arbitration proceeding shall be held at New Delhi or Circle or BA Headquarter (as the case may be).

10. Subject to the aforesaid conditions, provisions of the Arbitration and Conciliation Act, 1996 amended in 2015 and any statutory modifications or re-enactment thereof shall apply to the arbitration proceedings under this clause.

II. In the event of any dispute or difference relating to the interpretation and application of the provisions of commercial contracts between Central Public Sector Enterprises (CPSEs)/Port Trusts inter se and also between CPSEs and Government Department(s)/organizations(s) (excluding disputes concerning Railways, Income Tax, Customs & Excise departments). Such dispute or difference shall be taken up by either party for resolution through AMRCD as mentioned in DPE OM no. 4(1) 2013-

III. APPLICABLE LAW AND JURSDICTION

(a) The supply order for Goods 'or' Services, including all matters connected with this supply order shall be governed by the Indian law both substantive and procedural, for the time being in force and shall be subject to the exclusive jurisdiction of Indian Courts at the place from where the Purchase Order has been placed.

(b) Foreign companies, operating in India or entering into Joint Ventures in India, shall have to obey the law of land and there shall be no compromise or excuse for the ignorance of the Indian legal system in any way.

18. SET OFF:

Any sum of money due and payable to the supplier (including security deposit refundable to him) under this contract may be appropriated by the purchaser or the BSNL or any other person(s) contracting through the BSNL and set off the same against any claim of the Purchaser or BSNL or such other person or person(s) for payment of a sum of money arising out of this contract or under any other contract made by the supplier with the Purchaser or BSNL or such other person(s) contracting through the BSNL. In case of set off of the security deposit against any claim of the purchaser or BSNL or such other person or person(s) for payment of a sum of money arising out of this contract or under any other contract made by the supplier with the Purchaser or BSNL or such other person(s) contracting through the BSNL, the GST on such set off will be borne by the supplier. GST would not be liable on security deposit. But if supplier's security deposit is set off against any claim of the purchaser or BSNL or such other person or person(s) for payment of a sum of money arising out of this contract or under any other contract made by the supplier with the Purchaser or BSNL or such other person(s) contracting through the BSNL, then GST would be levied on such amount as being set off'.

19. TAX INDEMNITY CLAUSE:

BSNL has the right to recover Input Tax Credit loss suffered by it due to any mis-declaration on invoice by the supplier.

20. ACTION BY BSNL AGAINST BIDDER(S) IN CASE OF DEFAULTS

In case of defaults by bidder(s) as mentioned in Appendix-1 of Section-4 Part-A of BSNL Procurement Manual 2014 revised, action will be taken by BSNL as mentioned in Appendix-1 in addition to the existing clauses of this tender.

----- END OF SECTION V -----

SECTION-VI**E-tendering Instructions to Bidders****General**

The Special Instructions (for e-Tendering) supplement 'Instruction to Bidders', as given in this Tender Document. **Submission of Online Bids is mandatory for this Tender.**

E-Tendering is a new methodology for conducting Public Procurement in a transparent and secured manner. Suppliers/ Vendors will be the biggest beneficiaries of this new system of procurement. For conducting electronic tendering, BSNL, has decided to use the E tender portal (<https://etenders.gov.in/eprocure/app>) name) through E- tender portal, Benefits to Suppliers are outlined on the Home-page of the e tender portal.

Instructions**1. Tender Bidding Methodology**

Sealed Bid System – 'Single Stage – TWO Envelope'

2. Broad outline of activities from Bidders prospective

1. Procure a Digital Signing Certificate (DSC)
2. Register on e- tender portal (<https://etenders.gov.in/eprocure/app>)
3. Create Users and assign roles on E-TENDER PORTAL
4. View Notice Inviting Tender (NIT) on E-TENDER PORTAL
5. Download Official Copy of Tender Documents from E-TENDER PORTAL
6. Bid-Submission on E-TENDER PORTAL
 - a) Please take care to scan documents that total size of documents to be uploaded remains minimum. If required, documents may be scanned at lower resolutions say at 150 dpi. However, it shall be sole responsibility of bidder that the uploaded documents remain legible.
 - b) Utmost care may be taken to name the files/documents to be uploaded on E- TENDER PORTAL. There should be no special character or space in the name of file. Only underscores are allowed. The illustrative examples are given below:-

File name	Allowed or not allowed in E-TENDER PORTAL	Reason for allowed / not allowed
QA Certificate	not allowed	Space in between words / characters not allowed
QA Certificate(1)	not allowed	Special characters not allowed
QA_Certificate	allowed	Under score allowed between words /characters
QA_ Certificate	allowed	Upper & lower cases allowed

- c) It is advised that **all the documents to be submitted (See clause 5 of Section VI) are kept scanned or converted to PDF format in a separate folder on your computer before starting online submission.** BOQ may be downloaded and rates may be filled appropriately. This file may also be saved in a secret folder on your computer. The names & total size of each document (Preferably below 5 MB) may be checked.

- 1/727458/2024
7. Attend Public Online Tender Opening Event (TOE) on E- TENDER PORTAL :Opening of Techno-commercial Part
 8. View Post-TOE reports posted by BSNL on E- TENDER PORTAL.
 9. Attend Public Online Tender Opening Event (TOE) on E- TENDER PORTAL:Opening of Financial-Part (Only for Technical Responsive Bidders)
 10. View Post-TOE reports posted by BSNL on E- TENDER PORTAL.

For participating in this tender online, the following instructions are to be read carefully. These instructions are supplemented with more detailed guidelines on the relevant screens of the E-TENDER PORTAL.

3. Digital Certificates

For integrity of data and its authenticity/ non-repudiation of electronic records, and be compliant with IT Act 2000, **it is necessary for each user/contractor to have a Digital Certificate (DC)**. Also referred to as Digital Signature Certificate (DSC), of Class 2 or above, issued by a Certifying Authority (CA) licensed by Controller of Certifying Authorities (CCA) [refer <http://www.cca.gov.in>].

4. Registration

To use the e-tender portal ([\(\(https://etenders.gov.in/eprocure/app\)\)](https://etenders.gov.in/eprocure/app)). **Vendor/Contractor need to register on the e-tender portal.** The vendor should visit the home-page of the e tender portal (<https://etenders.gov.in/eprocure/app>) and go to the e-procure link then select **Bidders Manual Kit**.

To use the Electronic Tender[®] e tender portal (<https://etenders.gov.in/eprocure/app>) or through the circle website www.tender.bsnl.co.in portal name vendor needs to register on the e tender portal. Registration of each organization is to be done by one of its senior persons who will be the main person coordinating for the e-tendering activities. In ETS terminology, this person will be referred to as the Super User (SU) of that organization. For further details, please visit the website/e tender portal, and click on the 'Register Me' tab on the Home Page), and follow further instructions as given on the site.

Pay Annual Registration Fee as applicable.

Note: After successful submission of Registration details and Annual Registration Fee (as applicable), please contact the company providing e-tender. Helpdesk (as given below), to get your registration accepted/activated.

Helpdesk	CPPP Portal (eProcurement)
Telephone	0120-4001 002/4001 005/6277 787. <i>[between 9:30 hrs to 18:00 hrs on working days]</i>
Mobile Nos.	-
E-mail ID	Technical: support-eproc@nic.in Policy Related: cphp-doe@nic.in

1/727458/2024 **Method for submission of bid documents**

In this tender the bidder has to participate in e-tender online.

5.1. Offline submission

The bidder shall submit the following documents offline to AGM (Tenders) on or before the date & time of submission of bids specified in NIT, in a Sealed Envelope. The envelope shall bear (tender name), the tender number and the words 'DO NOT OPENBEFORE' (due date &time).

1. EMD-Bid Security in Original i.e. DD/Banker Cheque/Bank Guarantee /proof of payment if paid through NEFT/RTGS
2. DD/ Bankers cheque against payment of tender fee /proof of payment if paid through NEFT/RTGS.
3. Power of attorney in accordance with clause available in tender.
4. MSE registration certificate if the bidder is claiming concession for Bid cost and Bidsecurity.
5. Pass Phrase to open the tender document, if applicable.

5.2 Online submission.

Contents of first Envelope, i.e. Techno Commercial Envelope (Qualifying Bid)
A. Scanned Copy of Demand Draft /Bankers Cheque/Proof of payment if paid through NEFT/RTGS of requisite value for the cost of tender document in token of purchase of tender document as per NIT.
B. Scanned Copy of Demand Draft/ Bankers Cheque/BG/Proof of payment if paid through NEFT/RTGS of requisite value for the Bid Security/EMD as per NIT.
C. Scanned copy of Latest and valid MSE Certificate duly issued by NSIC/MSME(if applicable).
D. Scanned copy of PAN Card
E. Scanned copy of the EPF Registration Certificate.
F. Scanned copy of the ESI Registration Certificate.
G. Scanned copy of the GSTIN Registration Certificate.
H. Scanned copy of Solvency certificate from the banker of the tenderer: <i>For works costing up to Rs. 20 lakhs-solvency certificate should be of Rs. 5 lakhs; For works costing more than 20 lakhs– solvency certificate should be of Rs. 10 lakhs. The solvency certificate shall not be older than 3 months from the date of issue of NIT.(or) last three years audited financial statements duly certified by CA should be submitted and last three financial years cumulative turnover must be greater than equal to Total estimated cost of Tender.</i>
I. Scanned copy of the Experience Certificate(s) in the prescribed pro forma Annexure-B as per NIT.
J. Scanned copy of Documents in support of registration of the Company/Firm/Proprietorship: <ul style="list-style-type: none"> ➤ The registration of the firm, authenticated copy of partnership deed in cases of partnership firm. ➤ Attested copy of Articles of Association duly registered with Registrar of Company affairs, in case of Limited/Pvt. Limited Company. ➤ Duly executed Affidavit, stating that tenderer is the sole proprietor of the firm or any document issued by the taxation authorities stating that tenderer is the sole proprietor of the firm, in case of proprietorship firm.
K. Scanned copy of Registered Power of Attorney (if applicable).
L. Original Tender document duly signed on all pages.
M. Tenderers /Bidder's Profile duly filled in as per Section -III
N. Scanned copy of Near relative certificate(s) in the prescribed pro forma as per Annexure-A.

1/727458/2024	Q. Valid GST registration certificate or mention as unregistered dealer and a self-declaration along with the evidence that the bidder is not black listed by GST authorities.
	P. Scanned copy of duly filled and signed Bid Form, Section- II of tender.
	Q. Scanned copy of Duly completed declaration about Genuineness of Documents Certificates
Contents of second envelope i.e. Financial Envelope	
Schedule for Quoting the Rates(i.e. Section XX)	
R. Scanned copy of Last 3 years ITR.	

Note:

- (i) If some document is not applicable for the bidder then he has to upload scanned copy of paper mentioning 'The document <name> called vide clause is not applicable on us.
- (ii) If document asked for contains more than one page then all those pages may be uploaded in one PDF file.
- (iii) Last 3 years ITR has to be submitted.

6. Price Schedule /Schedule of Quoting Rates

Utmost care may kindly be taken to upload price schedule / Schedule of Quoting Rates. Any change in the format of Price Schedule / Schedule of Quoting Rates file shall render it unfit for bidding. Following steps may be followed-

1. Down load Price Schedule / Schedule of Quoting Rates.
2. Fill rates in down loaded Price Schedule / Schedule of Quoting Rates
3. Save filled copy of downloaded price schedule / Schedule of Quoting Rates file in your computer and remember its name & location for uploading correct file (duly filled in) when required.

For further instructions, the vendor should visit the home-page of the e tender portal (<https://etenders.gov.in/e procure/app>), and go to the **Bidders Manual Kit**. The compatible support software (PDF Converter, Java, etc) for online bid submission may be downloaded from E-tender portal or anywhere else.

The help information provided through 'E- TENDER PORTAL User-Guidance Center' is available in three categories – Users intending to Register / First-Time Users, Logged-in users of Buyer organizations, and Logged-in users of Supplier organizations. Various links are provided under each of the three categories.

Important

Note: It is strongly recommended that all authorized users of Supplier organizations should thoroughly peruse the information provided under the relevant links, and take appropriate action. This will prevent hiccups, and minimize teething problems during the use of E-TENDER PORTAL.

Note: The special instructions to contractors/Bidders for e-submission of bids online through <https://etenders.gov.in/e procure/app> which are mentioned below for ready reference-

1. Bidder should do the registration in the tender site <https://etenders.gov.in/e procure/app> name using the option available. Then the Digital Signature registration has to be done with the e-token, after logging into the site. The e-token may be obtained from one of the authorized Certifying Authorities such as NIC Certifying Authority (NICCA)/MTNL/SIFY/TCS / n-Code/e-Mudhra.

- 1/727458/2024
2. Bidder then login to the site thro' giving user id / password chosen during registration.
 3. The e-token that is registered should be used by the bidder and should not be misused by others.
 4. The Bidders can upload well in advance, the documents such as certificates, purchase order details etc., under **My Documents** option and these can be selected as per tender requirements and then send along with bid documents during bid submission.
 5. After downloading/getting the tender schedules, the Bidder should go thro' them carefully and then submit the documents as asked, otherwise, the bid will be rejected.
 6. If there are any clarifications, this may be obtained online thro' the tender site, or thro' the contact details. Bidder should take into account of the corrigendum published before submitting the bids online.
 7. Bidder, in advance, should get ready the bid documents to be submitted as indicated in the tender schedule and they should be in PDF/xls/rar/dwf formats. If there is more than one document, they can be clubbed together.
 8. The bidder reads the terms & conditions and accepts the same to proceed further to submit the bids.
 9. The bidder has to submit the tender document online well in advance before the prescribed time to avoid any delay or problem during the submission process.
 10. After the bid submission, the acknowledgement number, given by the e-tendering system should be printed by the bidder and kept as a record of evidence for online submission of bid for the particular tender.
 11. The **Tender Approving Authority (TIA)** will not be held responsible for any sort of delay or the difficulties faced during the submission of bids online by the bidders.
 12. The bidder should see that the bid documents submitted should be free from virus and if the documents could not be opened, due to virus, during tender opening, the bid is liable to be rejected
 13. The time settings fixed in the server side & displayed at the top of the tender site, will be valid for all actions of requesting, bid submission, bid opening etc., in the e-tender system. The bidders should follow this time during bid submission.
 14. All the data being entered by the bidders would be encrypted using PKI encryption techniques to ensure the secrecy of the data. The data entered will not be viewable by unauthorized persons during bid submission & not be viewable by any one until the time of bid opening. Overall, the submitted tender documents become readable only after the tender opening by the authorized individual.
 15. The confidentiality of the bids is maintained since the secured Socket Layer 128 bit encryption technology is used. Data storage encryption of sensitive fields is done.
 16. The bidders are requested to submit the bids through online e-tendering system to the TIA well before the bid submission end date & time (**as per Server System Clock**).
 17. **The bidder should logout of the tendering system using the normal logout option available at the top right hand corner and not by selecting the (X) option in the browser.**
 18. If the bidder submits the bid in manual form, he should have already registered in the tender site and he has to inform the registration ID in the bid submitted otherwise his tender will not be considered.

For any other queries, the bidders are asked to contact through Mail : email id of the e tender portal service

Provider Technical - support-eproc@nic.lin

Policy Related - cphp-doe@nic.in

7. Key Instructions for Bidders

The following '**FOUR KEY INSTRUCTIONS for BIDDERS**' must be assiduously adhered to

1. Obtain individual Digital Signing Certificate (DSC or DC) well in advance of your first tender submission deadline on E-TENDER PORTAL.
2. Register your organization on E-TENDER PORTAL well in advance of your first tender submission deadline on E-TENDER PORTAL.
3. Get your organization's concerned executives trained on E-TENDER PORTAL using online training module well in advance of your tender submission deadline on E-TENDER PORTAL.
4. Submit your bids well in advance of tender submission deadline on E-TENDER PORTAL. As there could be last minute problems due to internet timeout, breakdown, etc.

(BSNL should not be responsible for any problem arising out of internet connectivity issues). While the first three instructions mentioned above are especially relevant to first-time users of E-TENDER PORTAL, the fourth instruction is relevant at all times.

8. Minimum Requirements at Bidders end

- Computer System with good configuration (Min P IV, 1 GB RAM, Windows XP)
- 2 Mbps Broadband connectivity with UPS.
- Microsoft Internet Explorer 6.0 or above
- Digital Certificate(s) for users.

----- END OF SECTION VI -----

SECTION VII
SPECIAL CONDITIONS OF CONTRACT

1. GENERAL :

- 1.1. The work shall be accepted only after Acceptance Testing carried out by BSNL team, designated by the BSNL, as per prescribed schedule and work/material passing the test successfully.
- 1.2. The BSNL reserves the right to disqualify such bidders who have a record of not meeting contractual obligations against earlier contracts entered into with the BSNL.
- 1.3. The BSNL reserves the right to black list a bidder for a suitable period in case he fails to honour his bid without sufficient grounds.
- 1.4. The BSNL reserves the right to counter offer price(s) against price(s) quoted by any bidder.
- 1.5. Any clarification issued by BSNL, in response to query raised by prospective bidders shall form an integral part of bid documents and it may amount to amendment of relevant clauses of the bid documents.
- 1.6. Tender will be evaluated as a single package of all the items given in the price schedule.
- 1.7. All work to be executed under the contract shall be executed under the direction and subject to the approval in all respects of the Divisional Engineer or Site Engineer in-charge of worksite who shall be entitled to direct at what point or points and what manner they are to be commenced.
- 1.8. If the contractor shall desire an extension of time for completion of the work on the grounds of unavoidable hindrance in execution of work or any other ground he shall apply in writing to the Divisional Engineer on the same day of occurrence of hindrance on account of which he desires such extension as aforesaid. In this regard the decision of **Tender Approving Authority** shall be final.
- 1.9. If at any time after the commencement of the work, the BSNL may feel that execution of whole or part of work, as specified in the tender is not required to be carried out, then the BSNL shall give notice in writing of the fact to the contractor who shall have no claim to any payment of compensation whatsoever on account of any profit or advantage which he might have derived in consequence of the full amount of the work not having been carried out neither shall he have any claim for compensation by reason of any alterations having been made in the original specifications, drawings, designs and instructions which shall involve any curtailment of the work as originally contemplated.
- 1.10. Whenever any claims against the contractor for the payment of a sum of money arises out of or under the contract, the BSNL shall be entitled to recover such sum by appropriating in part or whole of the security deposit of the contractor, and to sell any Government promissory notes etc., forming the whole or part of such security or Final bill pending against any contract with the BSNL. In the event of the security being insufficient or if no security has been taken from the contractor, then the balance or the total sum recoverable as the case may be, shall be deducted from any sum then due or which at any time thereafter may become due to the contractor under this or any other contract with BSNL. Should this sum be not sufficient to cover the full amount recoverable the contractor shall pay to BSNL on demand the balance remaining due.
- 1.11. No official of Gazetted rank or other Gazetted officer employed in Engineering or administrative duties in an Engineering Department or any other Department of the Government of India is allowed to work as a contractor for a period of two years after his retirement from Government service without the previous permission of Government of India. This contract is liable to be cancelled if either the contractor or any of his employee is found at any time to be such a person who had not obtained the permission of Government of India as aforesaid before submission of the engagement in the contractor's service as the case may be.

1/727458/2024

1.12. In the event of the contractor being adjudged insolvent or going voluntarily into liquidation of having received order or other order insolvency act made against him or in the case of company, of the passing of any resolution, or making of any order for winding up whether voluntarily or otherwise, or in the event of the contractor failing to comply with any of the conditions herein specified, the **Tender Approving Authority**, shall have the power to terminate the contract without any notice.

1.13. Without prejudice to any of the rights or remedies under this contract, if the contractor dies, the **Tender Approving Authority** on behalf of the BSNL can terminate the contract without compensation to the contractor. However, **Tender Approving Authority**, at his discretion may permit contractor's heirs to perform the duties or engagements of the contractor under the contract, in case of his death. In this regard the decision of **Tender Approving Authority** shall be the final.

1.14. In the event of the contractor, winding up his company on account of transfer or merger of his company with any other, the contractor shall make it one of the terms and stipulations of the contract for the transfer of his properties and business, that such other person or company, shall continue to perform the duties or engagement of the contractor under this contract and be subject to his liabilities there under.

1.15. Interpretation of the contract document:

1.15.1. The representative of **Tender Approving Authority** and the contractor shall in so far as possible by mutual consultation, try to decide upon the meaning and intent of the contract document. In case of disagreement, the matter shall be referred to the Competent Authority whose decision shall be final. Any change in the contract documents shall be set forth in writing by the representative of the parties hereto. It shall be the contractor's responsibility to thoroughly familiarize all of his supervisory personnel with the contents of all the contract documents.

1.2. Notification:

1.2.1. The contractor shall give in writing to the proper person or authority with a copy to the Divisional Engineer such notification as may be mandatory or necessary in connection with the commencement, suspension, resumption, performance and / or completion of the contracted work. All notice shall be given sufficiently in advance of the proposed operation to permit proper co-relation of activities and the contractor shall keep all proper persons to authorities involved and advised of the progress of operations throughout the performance of the work and/or with such other information and /or supporting figure and data as may from time to time as directed or required.

1.3. Shut down on account of weather conditions:

1.3.1. The contractor shall not be entitled to any compensation whatsoever by reason of suspension of the whole or any part of the work made necessary by the BSNL or deemed advisable on account of bad weather conditions or other Force majeure conditions.

2. STORES SUPPLIED BY THE BSNL:

At no point of time the contractor shall be issued stores of value more than the contractor's material security as per clause number 5 (i) of Section V. If at all, the work requires more amount of materials to be issued to the contractor, then the material security shall correspondingly be enhanced to an amount equal to cost of the material/stores to be issued before the issue of the store and the contractor will not have any objection to it.

The contractor shall transport (including loading and unloading) all stores issued to him from District Telecom Store, to the site of work at his own cost. The BSNL shall not pay any transportation charges to the contractor.

All materials supplied to the contractor by the BSNL shall remain the absolute property of BSNL and shall not be removed from site of the work except for use in the work and shall be open to inspection by the Representative of Tender Issuing Authority. In case the materials like cable and accessories are taken delivery of by the contractor and stored at the site office/store of the contractor such site office / store will also be treated "as site" for this purpose. Any such material remaining unused at the time of the abandonment, completion or determination of the contract shall be returned to the BSNL at a place informed to him by the BSNL, failing which the cost of the unused materials shall be deducted

1/727458/2024 in the contractor's material security or any of his pending bills or from any other security.

The contractor shall be responsible for the transportation of store, storage and safe custody of all material supplied to him by the BSNL, which is in the contractor's custody whether, or not installed in the work. The contractor shall satisfy himself regularly about the quantity and quality of the materials supplied to him and he will be responsible for any subsequent deterioration and discrepancy (inclusive of theft) in the quantity/ quality of the materials.

The contractor shall submit a proper account every month of all the materials supplied to him by the BSNL and those consumed for items of work. Any discrepancy of difference between the materials issued to the contractor and those consumed in the work as per the "BSNL's calculation" (which shall be final) will be charged to the contractor or deducted from his bills at 1.5 times of prevailing standard price including freight, handling charges, storage charges etc.

The contractor shall ensure that only the required materials are issued to him. Upon completion of work, the contractor shall return to the BSNL. at the later designated store in good condition, free of charges, any unused materials that were supplied by the BSNL.

EASEMENTS, PERMITS, LICENCE AND OTHER FACILITIES:

The contractor shall obtain/provide at his own cost all easements, permits and license necessary to do its work e.g.

- A) "Right of User" easements and permits.
- B) Railway and Highway crossing permits including bridge.
- C) Canal / Stream crossing permits.

The successful bidder will be required to prepare route diagram in required format as asked by RoW authorities free of cost and shall be responsible for obtaining "Right of User" easements & permits (RoW permission). But, tendering authority shall make necessary payments towards RoW charges.

The contractor shall be fully responsible for angling and obtaining all necessary easements, permits and licenses, for moving all construction equipment, tools, supplied materials and men across Railways and Highways, across public or private road as well as premises of any

public utility within the right of user and for bearing all costs that may be incurred in respect of the same. The contractor is to confine his operation to the provided construction "Right of User" unless it has made other arrangement with the particular property owners and / or tenants such other arrangements shall be entirely at the responsibility of the contractor as to cost and arrangement as also breach and claim and shall be entitled with a copy to the Divisional Engineer. The contractor will not be entitled to extra compensation for hardship and increase in cost by the cable trench being routed adjacent to or across other pipeline, Highways, Railways, telephones or power poles and wires or guy wires, embankments, cliffs, streams or other obstacles which may physically or otherwise in any manner, restrict or limit the use of the construction "Right of User". Such construction and such contingency shall be deemed to have been provided for in the rates.

At location where the OF cable trench is routed across or along railways or roads the contractor shall without extra cost provide and maintain such detours and road controls as are required by the railways or government or local agencies having jurisdiction.

Due to any reason, if above mentioned permits etc. could not be arranged in time then the extension of time limit shall be provided as per EOT clause given in tender document.

3. QUALITY OF WORK:

The BSNL shall be the final judge of the quality of the work and the satisfaction of the BSNL in respect thereof set forth in the contract documents. Laxity or failure to enforce compliance with the contract documents by the BSNL and / or its representative shall not manifest a change or intent of waiver, the

1/727458/2024 Attention being that, notwithstanding the same, the contractor shall be and remain responsible for complete and proper compliance with the contract documents and the specification therein. The representative of Tender Issuing Authority has the right to prohibit the use of men and any tools, materials and equipment which in his opinion do not produce work or performance to meet the requirement of the contract documents.

4. TAXES AND DUTIES:

Contractor shall pay all rates, levies, fees royalties, taxes and duties payable or arising from out of, by virtue of or in connection with and/or incidental to the contract or any of the obligations of the parties in terms of the contract documents and / or in respect of the works or operations or any part thereof to be performed by the contractor and the contractor shall indemnify and keep indemnified the BSNL from and against the same or any default by the contractor in the payment thereof. However, service tax (GST) shall be paid extra by BSNL as applicable..

5. PROTECTION OF LIFE AND PROPERTY AND EXISTING FACILITIES:

The contractor is fully responsible for taking all possible safety precaution during preparation for and actual performance of the works and for keeping the construction site in a reasonable safe condition. The contractor shall protect all life and property from damage or losses resulting from his construction operations and shall minimize the disturbance and inconvenience to the public.

If the excavation of trench alters the contours of the ground around road and highway crossing in such locations become dangerous to traffic, the contractor shall at his own cost, take all necessary precautions to protect public and shall comply with all the BSNL regulations as to placing of warning boards (Minimum size 3' x 2'), traffic signals, barricades, flags etc. at such location. If the contractor does not put the warning signal as per above directions, then a penalty of Rs. 500/- per day shall be levied on the contractor, till the directions are complied by the contractor. The contractor shall take due precautions to avoid damages to other pipe lines, water, mains, sewers, telephones, telegraphs and power conduits, laid wires poles and guy wires, railways, highways, bridges or other underground or above ground structure and/or property crossing or adjacent to the cable trench being excavated.

Attention of the contractor is drawn to the rules regarding laying of cables at road crossing, along Railways Bridges, Highways safety precautions while working in Public Street. The contractor in writing shall obtain the detailed engineering instructions from the Divisional Engineer of the area.

The contractor shall be solely responsible for location through approved non- destructive means and ensuring the safety of all existing underground pipeline, electrical cables, and or other structures.

The contractor shall be solely liable for all expense for and in respect of repairs and / or damage occasioned by injury of or damage to such underground and above structures or other properties and under take to indemnify the BSNL from and against all actions, cause of actions, damages, claims and demands what-so-ever, either in law or in equity and all losses and damages and costs (inclusive between attorney and client), charges and expenses in connection therewith and / or incidental thereto. The contractor shall take all responsibilities and risks in crossing other pipelines and cables and shall be responsible for protecting all such existing pipelines, poles, electric lines, sewers, cables or other facilities from damage by the contractor's operation in connection with the work. The contractor without cost of the BSNL shall promptly repair any damage incurred.

The current market value of any commodities lost as a result of any damage to the aforesaid existing facilities shall be paid by the contractor together with such additional sums necessary to absolve the personal of property damages, resulting there from.

6. LABOUR WELFARE MEASURES AND WORKMAN COMPENSATION:

6.1. Obtaining License before commencement of work:

The contractor shall obtain a valid labour license under the Contract Labour (R&A) Act 1970 and the Contract Labour (Regulation and Abolition) Central Rules 1971, before commencement of the work, and continue to have a valid license until the completion of work. The contractor shall also abide by the provisions of the Child Labour (Prohibition and Regulation) Act 1986. Any failure to fulfill this

1/727458/2024 requirement shall attract the penal provisions of this contract arising out of the resultant non-execution of work.

6.2. Contractors Labour Regulations:

6.2.1. Working hours:

Normally working hours of an employee should not exceed 9 hours a day. The workingday shall be so arranged that inclusive of interval for rest, if any, it shall not spread over more than 12 hours on any day. When a worker is made to work for more than 9 hours on any day or for more than 48 hours in any week he shall be paid over time for the extra hours put in by him.

Every worker shall be given a weekly holiday normally on a Sunday, in accordance with the provisions of Minimum Wages (Central) Rules 1960, as amended from time to time, irrespective of whether such worker is governed by the Minimum Wages Act or not.

Where the minimum wages prescribed by the Government, under the Minimum Wages Act, are not inclusive of the wages for the weekly day of rest, the worker shall be entitled to rest day wages, at the rate applicable to the next preceding day, provided he has worked under the same contractor for a continuous period of not less than 6 days. Where a contractor is permitted by the Engineer-in-charge to allow a worker to work on a normal weekly holiday, he shall grant a substituted holiday to him for the whole day, on one of the five days, immediately before or after the normal weekly holiday, and pay wages to such worker for the work performed on the normal weekly holiday at the overtime rate.

6.2.2. Display of Notice Regarding Wages Etc.

The contractor shall, before he commences his work on contract, display and correctly maintain and continue to display and correctly maintain, in a clear and legible condition in conspicuous places on the work, notices in English and in local Indian languages spoken by the majority of the workers, giving the minimum rates of the wages fixed under **Minimum Wages Act 1948**, the actual wages being paid, the hours of work for which such wages are earned, wages periods, dates of payments of wages and other relevant information.

6.2.3. Payment of Wages;

The contractor shall fix wage periods in respect of which wages shall be payable. No wage period shall exceed one month. The wages of every person employed as contract labour in an establishment or by a contractor, where less than one thousand such persons are employed, shall be paid before the expiry of seventh day and in other cases before the expiry of tenth day after the last day of the wage period in respect of which the wages are payable.

Where the employment of any worker is terminated by or on behalf of the contractor, the wages earned by him shall be paid before the expiry of the second working day from the date on which his employment is terminated.

All payment of wages shall be made on a working day at the work premises and during the working time and on a date notified in advance and in case the work is completed before the expiry of the wage period, final payment shall be made within 48 hours of the last working day.

Wages due to every worker shall be paid to him direct or to other person authorized by him in this behalf. The payment to the contract workers is to be paid through Account payee cheque or online in the presence of authorized representative of BSNL.

Wages shall be paid without any deductions of any kind except those specified by the Central Government by general or special order in this behalf or permissible under the Payment of Wages Act, 1936.

The contractor /bidders /supplier shall comply with all the applicable labour laws,

inter alia, the provisions of the **“Payment of Wages Act 1936, and the Minimum Wages Act 1948** or the modifications thereof or any other laws relating thereto and the rules made there under from time to time.

A notice showing the wages period and the place and time of disbursement of wages shall be displayed at the place of work and a copy sent by the contractor to the Engineer-in-charge under acknowledgement.

The contractor shall obtain from the site Engineer or any other authorized representative of the Engineer-

1/727458/2024 charge, as the case may be, a certificate under his signature at the end of the entries in the “Register of Wages” or the “Wage-cum-Muster Roll”, as the case may be, in the following form:-

“Certified that the amount shown in the column No... .. has been paid to the workman Concerned in my presence on.....at.....”

6.2.4. Fines and deductions which may be made from wages

6.2.4.1. The wages of a worker shall be paid to him without any deduction of any kind except the following:-

a) Fines

b) Deductions for absence from duty i.e. from the place or the places where by the terms of his employment he is required to work. The amount of deduction shall be in proportion to the period for which he was absent.

c) Deductions for damage to or loss of goods expressly entrusted to the employed person for custody, or for loss of money or any other deductions which he is required to account, where such damage or loss is directly attributable to his neglect or default,

d) Deduction for recovery of advances or for adjustment of overpayment of wages, advances granted shall be entered in a register.

e) Any other deductions, which the Central Government may from time to time, allow.

6.2.4.2. No fines should be imposed on any worker save in respect of such acts and omissions on his part as have been approved of by the Labour Commissioner.

6.2.4.3. No fine shall be imposed on a worker and no deduction for damage or loss shall be made from his wages until the worker has been given an opportunity of showing cause against such fines or deductions.

6.2.4.4. Every fine shall be deemed to have been imposed on the day of the act or omission in respect of which it was imposed.

6.2.5. Labour records

The contractor shall maintain a **Register of Persons employed** on work on contract in Form XIII of the Contract Labour (R&A) Central Rules 1971.

The contractor shall maintain a **Muster Roll** register in respect of all workmen employed by him on the work under Contract in Form XVI of the CL (R&A) Rules 1971. The contractor shall maintain a **Wage Register** in respect of all workmen employed by him on the work under contract in Form XVII of the CL (R&A) Rules 1971.

6.2.6. Register of accidents – The contractor shall maintain a register of accidents in such form as may be convenient at the work place but the same shall include the following particulars:

a) Full particulars of the labourers who met with accident.

b) Rate of wages.

c) Sex

d) Age

e) Nature of accident and cause of accident

f) Time and date of accident

g) Date and time when admitted in hospital

h) Date of discharge from the hospital

i) Period of treatment and result of treatment

j) Percentage of loss of earning capacity and disability as assessed by Medical Officer.

k) Claim required to be paid under Workmen’s Compensation Act.

l) Date of payment of compensation.

m) Amount paid with details of the person to whom the same was paid.

n) Authority by whom the compensation was assessed.

o) Remarks

The contractor shall maintain a Register of Fines in the Form XII of the CL (R&A) Rules-1971.

The Contractor shall display in a good condition and in a conspicuous place of work the approved list of

1/727458/2024 and omission for which fines can be imposed.

The contractor shall maintain a Register of deductions for damage or loss in form XX of the CL (R&A) Rules 1971.

The contractor shall maintain a Register of Advances in Form XXIII of the CL (R&A) Rules 1971.

The contractor shall maintain a Register of Overtime in Form XXIII of the CL (R&A) Rules 1971.

The contractor shall deposit EPF and ESI. subscription to concerned authorities of the person employed by him as per provision of EPF and ESI Acts and maintain the necessary records as per the requirement under EPF & ESI rules.

6.2.7. Attendance card-cum wage slip

The contractor shall issue an Attendance card cum wage slip to each workman employed by him. The card shall be valid for each wage period. The contractor shall mark the attendance of each workman on the card twice each day, once at the commencement of the day and again after the rest interval, before he actually starts work. The card shall remain in possession of the worker during the wage period under reference. The contractor shall complete the wage slip portion on the reverse of the card at least a day prior to the disbursement of wages in respect of the wage period under reference. The contractor shall obtain the signature or thumb impression of the worker on the wage slip at the time of disbursement of wages and retain the card with him.

6.2.8. Employment card

The contractor shall issue an Employment Card in the Form XIV of CL (R&A) Central Rules 1971 to each worker within three days of the employment of the worker.

6.2.9. Service certificate

On termination of employment for any reason whatsoever the contractor shall issue to the workman whose services have been terminated, a Service Certificate in the Form XV of the CL (R&A) Central Rules 1971.

6.2.10. Preservation of labour records

The Labour records and records of Fines and deductions shall be preserved in original for a period of three years from the date of last entries made in them and shall be made available for inspection by the Engineer-in-charge or Labour Officer or any other officers authorized by the BSNL in this behalf.

6.3. Power of labour officer to make investigations or enquiry

The labour officer or any person authorized by the Central Government on their behalf shall have power to make enquiries with a view to ascertaining and enforcing due and proper observance of Fair Wage Clauses and provisions of these Regulations. He shall investigate into any complaint regarding the default made by the contractor in regard to such provision.

6.4. Report of Investigating officer and action thereon

The Labour Officer or other persons authorized as aforesaid shall submit a report of result of his investigation or enquiry to the Engineer in-charge indicating the extent, if any, to which the default has been committed with a note that necessary deductions from the contractor's bill be made and the wages and other dues be paid to the labourers concerned. The Engineer in-charge shall arrange payments to the labour concerned within 45 days from the receipt of the report from the Labour Officer or the authorized officer as the case may be.

6.5. Inspection of Books and Slips

The contractor shall allow inspection of all the prescribed labour records to any of his workers or to his agent at a convenient time and place after due notice is received or to the Labour Officer or any other person, authorized by the Central Government on his behalf.

6.6. Submission of Returns

The contractor shall submit periodical returns as may be specified from time to time.

6.7. Amendments

The Central Government may from time to time add to or amend the regulations and on any question as to the application / interpretation or effect of those regulations.

1/727458/2024 INSURANCE :

7.1. Without limiting any of his other obligations or liabilities, the contractor shall at his own expense, take and keep comprehensive insurance including third party risk for the plant, machinery, men, materials etc. brought to the site and for all the work during the execution. The contractor shall also take out workmen's compensations insurance as required by law and undertake to indemnify and keep indemnified the BSNL from and against all manner of claims and demands and losses and damages and cost (including between attorney and client) charges and expenses that may arise in regard to same or that the BSNL may suffer or incur with respect to and / or incidental to the same. The contractor shall have to furnish originals and /or attested copies as required by the BSNL of the policies of insurance taken within 15 (fifteen) days of being called upon to do so together with all premium receipts and other papers related thereto which the department may require.

8. COMPLIANCE WITH LAWS AND REGULATION :

8.1. During the performance of the works the contractor shall at his own cost and initiative fully comply with all applicable laws of the land and with any and all applicable by-laws, rules, regulations and orders and any other provisions having the force of law made or promulgated or deemed to be made or promulgated by the Government, Governmental agency or BSNL, municipal board, Government of other regulatory or Authorized body or persons and shall provide all certificates of compliance therewith as may be required by such applicable law, By-laws, Rules, Regulations, orders and /or provisions. The contractor shall assume full responsibility for the payment of all contributions and payroll taxes, as to its employees, servants or agents engaged in the performance of the work specified in the contractor documents. If the contractor shall require any assignee or sub-contractor to share any portion of the work to be performed hereunder, the same may be assigned, sub-leased or sub-contracted to comply with the provisions of the clause and in this connection the contractor agrees as to undertake to save and hold the BSNL harmless and indemnified from and against any/all penalties, actions, suits, losses and damages, claims and demands and costs (inclusive between attorney and client) charges and expenses whatsoever arising out or occasioned, indirectly or directly, by failure of the contractor or any assignee or sub-contractor to make full and proper compliance with the said by-laws, Rules, Regulations, Laws and Order and provisions as aforesaid.

8.2. The contractor shall also comply with the rule and regulation of EPF & ESI as per government rule and regulation from time to time at his own cost and expenses. The contractor shall indemnify the BSNL from any act or action in future or during the course of work in this regards at his own cost and expense. Tender Issuing Authority reserves the right to withhold the contractor amount upto 25% of tender value from the bills of contractor/security deposit in case of non-compliance of these rule and regulation by the contractor.

9. TOOLS AND PLANTS

The contractor shall provide at his own cost all tools, plants appliances, implements, measuring instruments etc. required for proper execution of works. The contractor shall also supply without charge the requisite number of persons with the means and materials necessary for the purpose of setting out works, counting, weighing and assisting the measurements for examination at any time and from time to time. The contractor shall be responsible to make all arrangements, at his own cost for dewatering of trenches / ducts and de-gasification of the ducts before carrying out the work. The contractor shall also be responsible to make arrangements at his own cost, for water required for carrying of works at sites including curing of CC/RCC works, failing which the same may be provided by the Engineer-in-charge at the expense of the contractor and the expenses shall be deducted from any money due to the contractor under this contract or otherwise.

10. As per guidelines issued from CO ND vide letter no. F.No.CA/MMT/3-1/2011-14/ dtd 20.03.2014 and subsequent amendment vide F.No.CA/MMT/10-12/2019/Pt-1 dtd 05.02.2020 action will be taken on the defaulting vendors/ contractors as given below :

Appendix-1 to Section 4 Part A of Chapter 4
(Standard Tender Enquiry Document)

S.No	Default of the Bidder/Vendor	Action to be taken
A	B	C
1(a)	Submitting fake/forged	
	a) Bank Instruments with the bid to meet terms & condition of tender in respect of tender fee and/ or EMD;	i) Rejection of tender bid of respective Vendor. ii) Banning of business for 3 years which implies barring further dealing with the vendor for procurement of Goods & Services including participation in future tenders invited by BSNL for 3 years from date of issue of banning order. iii) Termination/ Short Closure of PO/WO, if issued. This implies non-acceptance of further supplies /work & services except to make the already received material work/complete work in hand.
	b) Certificate for claiming exemption in respect of tender fee and/ or EMD;	
and detection of default at any stage from receipt of bids till award of Letter of intent/APO/ issue of PO/WO.		
	Note-1: However, in this case the performance guarantee if alright will not be forfeited.	
	Note-2: Payment for already received supplies/ completed work shall be made as per terms & conditions of PO/ WO.	
1(b)	Submitting fake / forged documents towards meeting eligibility criteria such as experience capability, supply proof, registration with Goods and Services Tax, Income Tax departments etc and as supporting documents towards other terms & conditions with the bid to meet terms & condition of tender :	
	(i) If detection of default is prior to award of APO/ Letter of intent	i) Rejection of Bid & ii) Forfeiture of EMD /Action will be taken as per the bid security declaration form iii) Banning of business for upto three years which implies Barring further dealing with the vendor for procurement of Goods & Services including participation in future tenders invited by BSNL for up to three years from date of issue of banning order

I/727458/2024

S.No	Default of the Bidder/Vendor	Action to be taken
A	B	C
	(ii) <i>If detection of default after issue of APO/ Letter of intent but before receipt of PG/ SD (DD,BG etc.)</i>	i) Cancellation of APO/ Letter of intent, ii) Rejection of Bid & iii) Forfeiture of EMD/Action will be taken as per the bid security declaration form iv) Banning of business for upto three years which implies Barring further dealing with the vendor for procurement of Goods & Services including participation in future tenders invited by BSNL for upto three years from date of issue of banning order
	(iii) <i>If detection of default after Receipt of PG/ SD (DD,BG etc.) .</i>	i) Cancellation of APO/ Letter of intent ii) Rejection of Bid & iii) Forfeiture of PG/ SD. However on realization of PG/ SD amount, shall discharge the declaration given in lieu of bid security EMD iv) Banning of business for upto three years which implies Barring further dealing with the vendor for procurement of Goods & Services including participation in future tenders invited by BSNL for upto three years from date of issue of banning order
	iv) <i>If detection of default after issue of PO/ WO</i>	i) Termination/ Short Closure of PO/WO and Cancellation of APO/ Letter of intent ii) Rejection of Bid & iii) Forfeiture of PG/ SD. However on realization of PG/ SD amount, shall discharge the declaration given in lieu of bid security EMD iv) Banning of business for upto three years which implies Barring further dealing with the vendor for procurement of Goods & Services including participation in future tenders invited by BSNL for upto three years from date of issue of banning order
	Note-3: However, settle bills for the material received in correct quantity and quality if pending items do not affect working or use of supplied items.	
	Note-4: No further supplies are to be accepted except that required to make the already supplied items work.	

I/727458/2024

S.No	Default of the Bidder/Vendor	Action to be taken
A	B	C
2	If vendor or his representative uses violent/ coercive means viz. Physical / Verbal means to threatens BSNL Executive / employees and/ or obstruct him from functioning in discharge of his duties & responsibilities for the following :	
2	<p>a) Obstructing functioning of tender opening executives of BSNL in receipt/ opening of tender bids from prospective Bidders, suppliers/ Contractors.</p> <p>b) Obstructing/ Threatening other prospective bidders i.e. suppliers/Contractors from entering the tender venue and/ or submitting their tender bid freely.</p>	Banning of business for 3 years which implies Barring further dealing with the vendor for procurement of Goods & Services including participation in future tenders invited by BSNL for 3 years from date of issue of banning order.
3	Non-receipt of acceptance of Letter of intent/APO/ AWO and SD/ PG by L-1 bidder within time period specified in APO/ AWO.	Action will be taken as per the bid security declaration form
4.1	Failure to supply and/ or Commission the equipment and /or execution of the work at all even in extended delivery Schedules, if granted against PO/WO.	<p>i) Termination of PO/ WO.</p> <p>ii) Under take purchase/ work at the risk & cost of defaulting vendor.</p> <p>iii) Recover the excess charges if incurred from the PG/ SD and outstanding bills of the defaulting Vendor.</p>
4.2	Failure to supply and/ or Commission the equipment and /or execution of the Work in full even in extended delivery schedules, if granted against PO/WO.	<p>i) Short Closure of PO/ WO to the quantity already received by and/ or commissioned in BSNL and/ or in pipeline provided the same is usable and/or the Vendor promises to make it usable.</p> <p>ii) Under take purchase/ work for balance quantity at the risk & cost of defaulting vendor.</p> <p>iii) Recover the excess charges if incurred from the PG/ SD and outstanding bills of the defaulting Vendor.</p>

I/727458/2024

S.No	Default of the Bidder/Vendor	Action to be taken
A	B	C
5.1	The supplied equipment does not perform satisfactory in the field in accordance with the specifications mentioned in the PO/WO/Contract.	i) If the material is not at all acceptable, then return the non-acceptable material (or its part) & recover its cost, if paid, from the o/s bills/ PG/ SD. OR ii) If the material is inducted in network & it is not possible to return it and/ or material is acceptable with degraded performance, the purchaser may determine the price for degraded equipment (Financial penalty = Price – price determined for degraded equipment) himself and/ or through a committee. Undertake recovery of financial penalty from outstanding dues of vendor including PG/ SD.

Sl. No	Default of the Bidder/Vendor	Action to be taken
A	B	C

I/727458/2024

5.2	Major quality problems (as established by a joint team / committee of User unit(s) and QA Circle) / performance problems and non-rectification of defects (based on reports of field units and QA circle).	<p>i) If the material is not at all acceptable, then return the non-acceptable material (or its part) & recover its cost, if paid, from the o/s bills/ PG/ SD;</p> <p>OR</p> <p>ii) If the material is inducted in network & it is not possible to return it and/ or material Is acceptable with degraded performance, the purchaser may determine the price for degraded equipment (Financial penalty = Price – price determined for degraded equipment) himself and/ or through a committee. Undertake recovery of financial penalty from outstanding dues of vendor including PG/ SD; and</p> <p>iii) Withdrawal of TSEC/ IA issued by QA Circle.</p>
6	<p>Submission of claims to BSNL against a contract</p> <p>(a) for amount already paid by BSNL</p> <p>(b) for Quantity in excess of that supplied by Vendor to BSNL.</p> <p>c) for unit rate and/ or amount higher than that approved by BSNL for that purchase.</p>	<p>i) Recovery of over payment from the outstanding dues of Vendor including PG & SD etc. and by invoking ‘Set off’ clause 21 of Section 5 Part A or by any other legal tenable manner.</p> <p>ii) Banning of Business for 3 years from date of issue of banning order or till the date of recovery of over payment in full, whichever is later</p>
	Note-5: The claims may be submitted with or without collusion of BSNL Executive/ employees.	
	Note-6: This penalty will be imposed irrespective of the fact that payment is disbursed by BSNL or not.	

I/727458/2024	<p>7</p> <p>Network Security/ Safety/Privacy:-</p> <p>a. If the vendor tampers with the hardware, software /firmware or in any other way that a) Adversely affects the normal working of BSNL equipment(s) and/ or any other TSP through BSNL.</p> <p>b) Disrupts/Sabotages functioning of the BSNL network equipments such as exchanges, BTS, BSC/ MSC, Control equipment including IN etc., transmission equipment but not limited to these elements and/ or any other TSP through BSNL.</p> <p>c) tampers with the billing related data/ invoicing/ account of the Customer/ User(s) of BSNL and/ or any other TSP(s).</p> <p>d) hacks the account of BSNL Customer for unauthorized use i.e. to threaten others/ spread improper news etc.</p> <p>e) undertakes any action that affects/endangers the security of India.</p>	<p>i) Termination of PO/ WO.</p> <p>ii) Banning of business for 3 years which implies barring further dealing with the vendor for procurement of Goods & Services including participation in future tenders invited by BSNL for 3 years from date of issue of banning order.</p> <p>iii) Recovery of any loss incurred on this account from the Vendor from its PG/ SD/ O/s bills etc.</p> <p>iv) Legal action will be initiated by BSNL against the Vendor if required</p>
8	<p>If the vendor/contractor is declared bankrupt or insolvent or its financial position has become unsound and in case of a limited company, if it is wound up or it is liquidated.</p>	<p>i) Termination/ Short Closure of the PO/ WO.</p> <p>ii) Settle bills for the quantity received in correct quantity and quality if pending items do not affect working or use of supplied items.</p> <p>iii) No further supplies are to be accepted except that required to make the already supplied items work.</p> <p>iv) In case of turnkey projects, If the material is commissioned and is usable without any degradation of performance, then settle bills for the acceptable equipment/ material (or its part).</p>

I/727458/2024

<p>8</p>		<p>v) In case of turnkey projects, if the material is inducted in network & it is not possible to return it and/ or material is acceptable with degraded performance, the purchaser may determine the price for degraded equipment (Financial penalty = Price – price determined for degraded equipment) himself and/ or through a committee. Undertake recovery of financial penalty from outstanding dues of vendor including PG/ SD.</p>
<p>9</p>	<p>In the event of the vendor/contractor, its proprietor, Director(s), partner(s) is / are convicted by a Court of Law following prosecution for Offences involving moral turpitude in relation to the business dealings.</p>	<p>i) Termination/ Short Closure of the PO/ WO. ii) Settle bills for the material received in correct quantity and quality if pending items do not affect working or use of supplied items. iii) No further supplies are to be accepted except that required to make the already supplied items work. iv) In case of turnkey projects, If the material is commissioned and is usable without any degradation of performance, then settle bills for the acceptable equipment/ material (or its part). v) In case of turnkey projects, If the material is inducted in network & it is not possible to return it and/ or material is acceptable with degraded performance, the purchaser may determine the price for degraded equipment (Financial penalty = Price – price determined for degraded equipment) himself and/ or through a committee. Undertake recovery of financial penalty from outstanding dues of vendor including PG/ SD.</p>

I/727458/2024

10	<p>If the vendor/contractor does not return/refuses to return BSNL's dues: a) in spite of order of Arbitrator.</p>	<p>(i) Take action to appoint Arbitrator to adjudicate the dispute. (ii) Termination of contract, if any. (iii) Banning of business for 3 years which implies barring further dealing with the vendor for procurement of Goods & Services including participation in future tenders invited by BSNL from date of issue of banning order or till the date by which vendor clears the BSNL's dues, whichever is later. (iv) Take legal recourse i.e. filing recovery suite in appropriate court</p>
	<p>b) in spite of Court Orders.</p>	<p>i) Termination of contract, if any. ii) Banning of business for 3 years which implies barring further dealing with the vendor for procurement of Goods & Services including participation in future tenders invited by BSNL from date of issue of banning order or till the date by which vendor clears the BSNL's dues, whichever is later.</p>
11	<p>If the Central Bureau of Investigation/ Independent External Monitor (IEM) / Income Tax/Goods and Services Tax / Custom Departments recommends such a course</p>	<p>Take Action as per the directions of CBI or concerned department.</p>
12	<p>The following cases may also be considered for Banning of business: (a) If there is strong justification for believing that the proprietor, manager, MD, Director, partner, employee or representative of the vendor/ supplier has been guilty of malpractices such as bribery, corruption, fraud, substitution of tenders, interpolation, misrepresentation with respect to the contract in question. (b) If the vendor/contractor / supplier fails to execute a contract or fails to execute it satisfactorily beyond the provisions of Para 4.1 & 4.2.</p>	<p>Banning of business for 3 years which implies Barring further dealing with the vendor/contractor for procurement of Goods & Services including participation in future tenders invited by BSNL for 3 years from date of issue of banning order.</p>

I/727458/2024	(c) If the vendor/contractor / supplier fails to submit required documents/information, where required.	
12	(d) Any other ground which in the opinion of BSNL is just and proper to order for banning of business dealing with a vendor/contractor / supplier.	

Note 13: The above penalties will be imposed provided it does not clash with the provision of the respective tender.

Note 14:-In case of clash between these guidelines & provision of invited tender, the provision in the respective tender shall prevail over these guidelines.

Note 15: Banning of Business dealing order shall not have any effect on the existing/ ongoing works/ AMC /CAMC which will continue along with settlement of Bills.

Note 16: However settle bills for the material received/work completed in correct quantity and quality if pending items/work do not affect working or use of supplied items.

Note 17: No further supply/work are to be accepted/executed except that required to make the already supplied/executed items work.

----- END OF SECTION VII -----

SECTION-VIII
IMPORTANT INSTRUCTIONS

1. After the work commences the contractor or his authorized representative(s) shall be present at the site. The representative shall be authorized by the Divisional Engineer in charge based on the contractor's request.
2. Work shall be recorded in the site register by the site Engineer. The contractor or his authorized representative shall sign in the site register held by the site Engineer.
3. Since the time provided for the work is only a few days/weeks, all the communications shall be done at the site. If the contractor or his authorized representatives shall not sign the register, then it shall be considered that nobody is present at the site. Then only written communication shall be sent through registered post.
4. If the contractor does not provide the barricades, warning cones, warning tapes and work notice board, 5% additional penalty shall be levied. The same shall be provided by BSNL and 150% of the cost of the items shall be recovered from the contractor.
5. Due to underground utilities, if the manhole cannot be constructed at the site shown, the decision of the site engineer shall be final and binding on the contractor. If it is decided to shift the man hole within the neighborhood, the contractor shall construct at the place shown by the site engineer.
6. The right of way (RoW) shall be obtained by the successful contractor on behalf of BSNL, including various permission from authorities like water, power, utilities, traffic police etc. The RoW charges shall be paid by BSNL. The work shall be carried out as per terms and conditions and time lines mentioned in the RoW permission. The contractor shall deploy adequate men and machine so as to complete the work within permitted time.

PERMISSION (ROW) TO BE OBTAINED BY THE CONTRACTOR:

- 6.1 The approved bidder shall obtain way leave permission (right of way) from the concerned road authorities, including permission for working from Police/District authorities. This will include the works of preparing the requisition for permission along with the necessary drawings as required by the highway authorities, get the same duly signed by the Divisional Engineer- in charge of the work, and submit the same to the road authorities. They shall pursue the case on a continuous basis and get the permission in the shortest time. The rate quoted for trenching shall also include the charges for undertaking the work to get permission. No separate rates will be applicable for getting permission.
- 6.2. The contractor shall get the permission within 30 days of Letter of Intent (LOI). This intimation may also be conveyed telephonically or through telegram in order to reduce delay. The contractor shall forthwith start the process of survey, preparation and submission of application on behalf of BSNL along with relevant drawings to the concerned authority and co-ordinate for getting permission.
- 6.3. In case the contractor fails to obtain the permission within the specified time of 30 days, from the date of intimation of the acceptance of tender (LOI), a penalty of Rs.20,000/- with applicable GST will be imposed and deducted from the amounts due to the contractor, as time is the essence of the contract.
- 6.4. In cases the permission cannot be obtained within 30 days, due to reasons beyond the contractor's ability, the time frame can be further relaxed by 15 days by DGM, if the reasons are found

I/727458/2024

to be genuine, without imposing of penalty

6.5. The permission should be obtained in the most cost effective method for BSNL. The contractors should pursue to get the least restoration charges, and get the lowest BT cutting charges. The permission shall be applied under the supervision of the SDE-in-charge, and after satisfaction of the Divisional Engineer -in -charge.

6.6. The restoration charges shall be paid to the highways authorities directly by BSNL on obtaining the estimate along with written permission; provided, a) the rates are as per standard rates of the respective agency; b) the stretch of BT/ Berm are not more than the actuals. c) the width payable shall be for ≤ 60 cm only. Where the widths being charged by the respective agency is higher, the approval of DGM shall be taken.

6.7. It is the responsibility of contractor to obtain the security deposit submitted to the respective agencies/authorities like road authorities, Police/District authorities/ authorities concerned after completion of works. NOC has to be obtained by the contractor from the agencies/authorities. Final bill & security deposit of the contractor to the extent of security deposit submitted to the agencies/authorities will be settled only after obtaining the security deposit from the agencies/authorities or after obtaining the NOC from the agencies/authorities involved after completion of work & proper restoration by the contractor.

7. If the work extends beyond the time given in the work order. BSNL shall not provide the Right of Way. The permissions from Corporation and Police shall be obtained by the contractor. **If the contractor finds the time allowed for completion of work to be less, he may accordingly deploy more men/machines to complete the work in time.**

8. If the work is not progressing as per the schedule, the work may be either restricted or terminated.

9. If the manhole work is abandoned after commencing, the work may be either restricted or terminated.

10. In both the cases where the work is either restricted or terminated, apart from invoking necessary tender clauses, the contractor shall not be given tender document for a similar work under Tender Issuing Authority, for a period of one year.

11. After the ducts are laid by either Open trenching method or by HDD, the duct integrity test shall be carried out by the contractor on the next day. This is to facilitate the Manhole contractor to commence the manhole work.

12. If any one or more number of ducts is found to fail the duct integrity test, additional laying/HDD of pipe/s shall be carried out by the contractor at no extra cost. The cost of the damaged pipe(s) shall be recovered from the contractor with additional 17.5% towards Overhead charges.

13. After the re-laying of additional pipe(s), duct integrity test shall be performed in the failed segment, on all the ducts once again.

14. After the ducts are laid by either Open trenching method or by HDD, if duct integrity test is not carried out by the contractor, the test shall be carried out by BSNL and only 50% of the actual payment shall be made to the contractor for PLB pipe laying.

15. For any unfinished work BSNL shall not effect any payment.

16. The material abandoned shall be the property of BSNL. No claim in this regard from the contractor shall be entertained.

17. BSNL reserves the right to construct the manhole, from the stage at which the construction is abandoned by the contractor. This is because the pipe is already terminated at the said location.

18. Rate should be quoted in figures as well as in words and corrections should be attested, otherwise tender shall be rejected.

19. It is the responsibility of the contractor to keep the pipes inside the existing cement concrete duct, where the HDD/OT commences. Duct poking shall be arranged by BSNL.

20. The contractor shall restore the cut portions of BT/Concrete roads to their original conditions

I/727458/2024

immediately on completion of the pipe laying works. If the restoration work is not satisfactory with reference to the standards prescribed by the Corporation / Highways, the amount equal to the charges as claimed by the Corporation/Highways will be recovered from the contractor.

21. The contractor shall deploy as many machines as required for the timely completion of the work.

22. The fact that the contractor is working simultaneously in one or more sections in the same Division/other Divisions, will not absolve him from the responsibility of completing the work in time.

23. Wastage of PLB pipes will be permitted to an extent of 5% of the completed length as measured on the road surface.

24. In case of wastage of PLB pipes beyond 5% the cost of PLB pipe will be recovered from the contractor with additional 17.5%.

----- END OF SECTION VIII-----

SECTION IX
(PART A)
SCOPE OF WORK AND JURISDICTION OF CONTRACT

1.1 SCOPE OF WORK

The scope of the work has been defined in NIT and given again as below-

A. Under Ground Optical Fibre Cable: The steps involved in OF Cable construction are as under:

- a. Excavation of trench up to a nominal depth of 165 cms., according to Construction specifications along National/State Highways/other roads and also in city limits as mentioned in the notice inviting tender.
- b. Laying of PLB pipes/coils coupled by PLB sockets in excavated trenches, on bridges and culverts, drawing of 6 mm Polypropylene para pro rope (P.P.rope) through the PLB pipe ends at every manhole by PLB end caps of suitable size.
- c. Providing of mechanical protection by R.C.C. Pipes/GI pipes and/or concreting/chambering according to construction specifications, wherever required.
- d. Fixing of GI pipes/troughs with clamps at culverts/bridges and/or chambering or concreting of G.I. Pipes/troughs, wherever necessary.
- e. Back filling and dressing of the excavated trenches according to construction specifications.
- f. Opening of manholes (of size 2 meters x 1 meters x 1.65 meters depth), replacing existing 6mm P.P. ropes by 8mm P.P. rope (from manhole to manhole) for ensuring smooth passage for pulling the cable. Pulling of Optical Fibre Cable with proper tools and accessories as per construction specifications. Sealing of both ends of the manholes by hard rubber bush of suitable size to avoid entry of rodents into the PLB pipes, putting split PLB pipes over cable in the manhole to protect the bare cable in the pulling manhole. Back filling and dressing of manholes.
- g. Digging of pit of size 2 meter x 2 meter x 1.8 meter (depth) for construction of jointing chamber at approximately every two kilometers of internal size of 1.5 meter x 1.5 meter x 1.2 meter using bricks and mortar or fixing pre-cast jointing chamber of internal diameter of 1.2 meter and minimum height of 0.3 meter, filling of jointing chamber with clean sand, placing either pre-cast RCC cover or stone of suitable size on jointing chamber to protect the joint and back filling of jointing chamber with excavated soil.
- h. Digging of pits 1 meter towards jungle side at every manhole and jointing chamber to a depth of 60 cms., fixing of route indicator/joint indicator, concreting and back filling of pits, painting of route indicators with yellow colour and joint indicator by red colour and sign writing denoting route/joint indicator number, as per construction specifications.
- i. Documentation.

1.2 BRIEF DESCRIPTION OF WORK

a. The work which shall be carried out as per Construction Specifications issued by BSNL contained in this bid document, involves Conventional Trenching and Reinstatement (CTR); Horizontal Directional Drilling (HDD); Related Allied Works (RAW).

The various works can be summarized as below. The construction specification given below covers Conventional trenching and reinstatement and allied works. The specification for horizontal directional drilling is specified.

- b. Open trenching at 165 cm depth & width of 45 cms at top and 30 cms at bottom.
- c. Permanently lubricated PLB pipes will be supplied by BSNL in coils of varying lengths from 200 meter onwards. Spools should be de-coiled using jack mechanism and bends removed by proper forming so that the pipes are straight. This will be part of contractor works and no extra payment will be paid. In addition to the laying of PLB pipes, there may be cases where PVC pipes of straight lengths may have also to be provided.
- d. Whenever there is any doubt in any of the construction step, BSNL's Engineering Instructions on

Under Ground / Over Head Optical Fibre Cable Laying Works shall be referred.

Preparation of Documents: The documents should be prepared in the spiral bound sets which will contain the route diagram indicating the road, Number of Posts with marking, Jointing Chambers, important land marks and other utilities running parallel or crossing the route. The documents should be prepared in computer using drawing tools of MS Office and six bound sets should be made over along with a soft copy. The drawings will be accepted by the Engineer in charge after verifying the correctness, usability. The documentation cost is part of the rate quoted in carrying out the work and no separate payment will be made for preparation of documents.

1.3 SPECIFICATION FOR CONCRETING:

1.3.1 The nominal dimension of concreting shall be as per SOR

1.3.2 Any damages caused to the existing structure such as Foot path shall be repaired and original condition restored to the satisfaction of Road Authorities.

1.3.3 The Contractor shall provide all the material required for the cement concreting work at the site. Cement concrete Mixture used shall be of 1:2:4 (1 cement: 2 coarse sand (zone-III):4 graded stone aggregate 20 mm nominal size)

1.3.4 Portions where cement concreting have been done shall be cured with sufficient amount of water for reasonable time to harden the surface. After curing, refilling of the balance depth of the Pit has to be done with excavated soil. It may be noted that no extra payment is admissible for arranging material, labor tools and machine while carrying out the work.

1.4 STORES TO BE PROCURED BY THE CONTRACTOR:

1.4.1 The items to be procured by the contractor will include the following:

- a) Tension/ Suspension poles and all necessary accessories/fittings, pulley as per SOR spec .
- b) River Sand
- c) Construction material, cement, jelly, sand etc., for concreting works
- d) Warning boards, warning cones, flags, signals, barricades, electric warning lamps and bands.
- e) Any other material used in this work.

1.4.2 All materials for use shall be new and duly tested as per approved standards and shall comply the material specifications. Where no spec is specified, it shall conform to BIS/ISI/CPWD standards. The Poles shall be as per IS 2713/1986 (Part- I- II). All other parameters shall be as per IS 2713 / 1986

1.4.3 Necessary Telecom Engineering Centre (TEC)/ TSEC issued by the Quality Assurance Circle of BSNL is to be produced by the contractor. The stores procured by the contractor will be tested for meeting standards prescribed and only such material which meets the standards will be accepted and allowed to be utilized. This doesnot absolve the contractor from his responsibility to replace and redo the work in case of failure of the construction during 1 year from date of completion of construction.

1.5 SPECIFICATION FOR STONE AGGREGATES, COARH SAND, FINE SAND:

1.5.1 **Stone aggregate:** Stone aggregate to be used in the work shall be hard broken stone and shall be conform to latest CPWD specification.

1.5.2 **Coarse sand:** Coarse sand to be used shall conform to latest CPWD specification.

Fine sand: Fine sand for finishing to be used in the work shall conform to latest CPWD specifications.

Note: Where only one variety of sand is available, the sand will be sieved for use in finishing work as directed by the Engineer-in-charge in order to obtain smooth surface and nothing extra will be paid on this account.

2 PRELIMINARY INSPECTION:

2.1.1 Before offering completed works for acceptance testing to Engineer-in-charge, the contractor shall complete all checks and tests as required and submit report.

2.1.2 The Site Engineer, Engineer-in-charge and the officers of BSNL including A/T personnel will inspect the work from time to time during the course of construction. The Engineer-in-charge will also conduct a preliminary inspection before offering for acceptance testing and any defects pointed out shall

1/727458/2024 rectified forthwith at contractor's expense.

2.1.3 In case the completed duct system do not pass the final acceptance testing or checks as required, the contractor shall bear all costs in this regard and re-offer works after rectification for preliminary inspection of the Engineer-in-charge.

3.0 FINAL INSPECTION AND A/T:

The Engineer-in-charge after his satisfactory preliminary inspection shall offer the works for final inspection to the Acceptance Testing Unit (hereinafter called A/T Unit). **The route index/offset diagram should be prepared by the contractor and made over to the A/T unit in advance.** The A/T unit will randomly check the Works as per construction practices.

The A/T Unit and Site Engineer shall jointly inspect completed work and confirm that the work has passed all the checks and test prescribed in Acceptance Testing Schedules.

After completion of final inspection, the acceptance-testing unit shall issue the completion and testing reports in prescribed proforma. The A/T, completions Report shall be issued only after all the points have been attended to. The report shall normally released within 30 days from receipt of offer the Site Engineer.

No work shall be treated as complete until acceptance testing and quality control checks are completed and found satisfactory.

All the defects pointed out by the A/T unit or/and Engineer-in-charge shall be rectified and got re-tested by the contractor at his own cost before the work is treated as completed. The responsibilities of non-clearing the defects and thus non-completion of work shall always rest with the contractor. The rejection of the work shall be intimated to all concerned to ensure prompt action. All material, T & P, equipment labour and assistance required by Engineer-in-charge A/T Unit for preliminary testing of final A/T shall be provided by the contractor at his own cost.

The A/T report, offset diagrams and M-Book shall constitute the basic records of the routes to be maintained by the BSNL.

4.1 Disposal of Empty Cable Drums: The contractor shall be responsible to dispose of the empty cable drums after slinging of the cables. The cost of various sizes of empty cable drums recoverable from the contractor has been fixed taking into account the prevailing market rates as mentioned in this document.

4.2 Supply of Materials: There are some materials required to be supplied by the contractor for execution of work under this contract like Aerial accessories, Pulley, Bricks, Cement, sand for concreting of Posts etc., besides using other consumables which do/don't become the part of the asset. The contractor shall ensure that the materials supplied are of best quality and workmanship and shall be strictly in accordance with the specifications.

4.3 Permission from Authorities: The contractor shall accord necessary help in obtaining permission from HPPWD, NHAI, Local municipality, NHAI, Rail and forest authority. The cost of providing help in obtaining permission are subsumed in the standard scheduled rates and therefore no separate charges are payable on this account. However, the Charges payable to the Authorities shall be borne by BSNL.

COST OF WORK: The estimated cost of work is as mentioned in the Notice Inviting Tenders which has been worked out based on standard scheduled rates mentioned in this tender document. The actual value of work may vary based on the actual requirement but generally being limited to +/-25% of the contract value of the work. However, **in exceptional circumstances only**, due to change in scope of work or otherwise, any variation in the value of work may be permitted upto 50% of contract value with prior approval of the next higher authority after recording adequate reasons and justification for the same.

Clamping of DWC duct beneath /on the collar of the bridges: This work is a specialized work, while execution of the work depending upon the space available to fix the 110mm DWC duct under beneath / on the collar of the bridges with sufficient size of the clamp which will fix for the bridge and the contractor has to provide a certificate in case of any problem without any extra charges the agency has to do the maintenance for the next **three years** please.

NETWORK DIAGRAM FOR PROPOSED OFC LAYING FOR IIT SRICITY

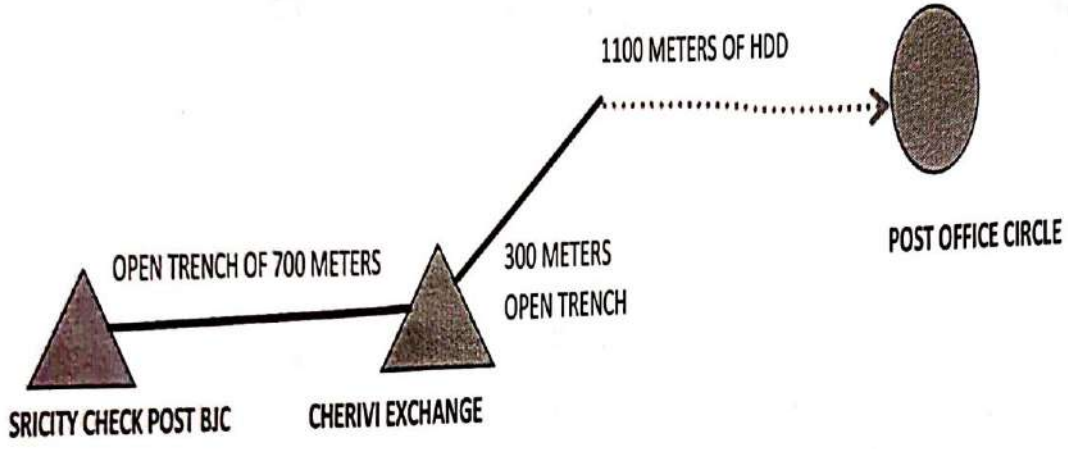

AGM PLG
सहायक महा प्रबंधक (योजना)
Asst. General Manager (Plg.).
भा.सं.नि.लि.का.महा प्र.दूरसंचार जिला
BSNL, O/o. G. M. Telecom District
तिरुपति / TIRUPATI - 517 501

DE MTCE PUTTUR

SECTION X

Pro-forma of Material Security Bond

(To be typed on non-judicial stamp paper of appropriate value)

Dated:.....

MATERIAL SECURITY BOND FORM

Whereas<Contract awarding authority>(hereinafter referred to as BSNL) Has issued an Award Letter no..... Dated .../.../20... for awarding the work of Optical Fibre Cable Laying work to M/s..... (hereafter referred to as “Contractor”) and the BSNL has asked them to submit a bank guarantee, towards material security, in favour of The CGMT,AP CO, BSNL BHAVAN,Vijayawada of Rs./- (hereafter referred to as “BG. Amount”) valid up to .../.../20... hereinafter referred to as “Validity Date”). Now at the request of the Contractor, We..... Bank Branch having (Address) and Regd office address as (Hereinafter called „the Bank”) agreed to give this guarantee as hereinafter contained:

1. We, “the Bank” do hereby undertake and assure to the BSNL that if in the opinion of the BSNL, the Contractor has in any way failed to observe or perform the terms and conditions of the said agreement or has committed any breach of its obligations there-under, the Bank shall on demand and without any objection or demur pay to the BSNL the said sum limited to BG Amount or such lesser amount as BSNL may demand without requiring BSNL to have recourse to any legal remedy that may be available to it to compel the Bank to pay the same.
2. Any such demand from the BSNL shall be conclusive as regards the liability of Contractor to pay to BSNL or as regards the amount payable by the Bank under this guarantee. The Bank shall not be entitled to withhold payment on the ground that the Contractor had disputed its liability to pay or has disputed the quantum of the amount or that any arbitration proceeding or legal proceeding is pending between Contractor and BSNL regarding the claim. Liability of the bank under this present being absolute and unequivocal.
3. We, the Bank further agree that the guarantee shall come into force from the date of its issue and shall remain in full force and effect up to its Validity date.
4. The Bank further agrees that the BSNL shall have the fullest liberty without the consent of the Bank and without affecting in any way the obligations hereunder to vary any of the terms and conditions of the said agreement or to extend the time for performance of the said agreement from any of the powers exercisable by BSNL against the Contractor and to forebear to enforce any of the terms and conditions relating to the said agreement and the Bank shall not be relieved from its liability by reason of such failure or extension being granted to Contractor or through any forbearance, act or omission on part of BSNL or any indulgence by BSNL to Contractor or any other matter or thing whatsoever which under the law relating to sureties would but for this provision have the effect of relieving or discharging the guarantor.
5. Notwithstanding anything herein contained; (a) The liability of the Bank under this guarantee is restricted to the BG Amount and it will remain in force up to its Validity date. (b) The guarantee shall stand completely discharged and all rights of the BSNL under this Guarantee shall be extinguished if no claim or demand is made on us in writing on or before its validity

1/727458/2024.

6. In case BSNL demands for any money under this bank guarantee, the same shall be paid through DD/Banker's Cheque/RTGS in favour of AO (Cash), O/o CGMT, BSNL BHAVAN, VIJAYAWADA.

7. The Bank guarantees that the below mentioned officer who have signed it on behalf of the Bank have authority to give this guarantee under its delegated power.

Place:

Date:

(Signature of the Bank Officer)
Rubber stamp of the bank
Authorized Power of Attorney Number:
Name of the Bank officer:
Designation:
Complete Postal address of Bank:
Telephone Numbers
Fax numbers.....

----- END OF SECTION X -----

Format for the BID SECURITY/ EMD Guarantee

(To be typed on Rs.100/- non-judicial stamp paper)

Sub: Bid Security/EMD guarantee.

Whereas M/s R/o (Hereafter referred to as Bidder) has approached us for giving Bank Guarantee of Rs./- (hereafter known as the “B. G. Amount”) valid up to/...../20... (hereafter known as the “Validity date”) in favour of AO(Cash) O/o CGMT BSNL Vijayawada (Hereafter referred to as BSNL) for participation in the tender of work of vide tender no.....Now at the request of the Bidder, We Bank Branch having(Address) and Regd. Office address as (Hereinafter called ‘the Bank”) agrees to give this guarantee as hereinafter contained:

2. We the Bank do hereby undertake to pay the amounts due and payable under this guarantee without any demur, merely on a demand from the BSNL stating that the amount claimed is due by way of loss or damage caused to or would be caused to or suffered by the BSNL by reason of breach by the said bidder(s) of any of terms or conditions contained in the said Agreement or by reason of the bidder (s) failure to perform the said Agreement. Any such demand made on the bank shall be conclusive as regards the amount due and payable by the Bank under this guarantee where the decision of the BSNL in these counts shall be final and binding on the bank. However, our liability under this guarantee shall be restricted to an amount not exceeding the “B. G. Amount”.
3. We undertake to pay to the BSNL any money so demanded notwithstanding any dispute or disputes raised by the bidder(s) in any suit or proceeding before any court or tribunal relating thereto our liability under this present being absolute and unequivocal. The Payment so made by us under this bond shall be valid discharge of our liability for payment there under and the bidder(s) shall have no claim against us for making such payment.
4. We the Bank further agree that the guarantee herein contained shall remain in full force and effect during the period that would be taken for the performance of the said agreement and that it shall continue to be enforceable till all the dues of the BSNL under or by virtue of the said Agreement have been fully paid and its claims satisfied or discharged or till BSNL Certifies that the terms and conditions of the said Agreement have been fully and properly carried out by the said bidder(s) and accordingly discharge this guarantee. Unless a demand or claim under this guarantee is made on us in writing or before the expiry of Validity date from the date hereof, we shall be discharged from all liability under this guarantee thereafter.

1/727458/2024 We the Bank further agree with the BSNL that the BSNL shall have the fullest liberty without our consent and without affecting in any manner our obligations hereunder to vary any of the terms and conditions of the said Agreement or to extend time of performance by the said bidder(s) from time to time or to postpone for any time or from time to time any of the powers exercisable by the BSNL against the said bidder(s) and to forbear or enforce any of the terms and conditions relating to the said agreement and we shall not be relieved from our liability by reason of any such variation, or extension being granted to the said Bidder(s) or for any forbearance, act or omission on the part of the BSNL or any indulgence by the BSNL to the said bidder(s) or by any such matter or thing whatsoever which under the law relating to sureties would, but for this provision, have effect of so relieving us.

- 6. Notwithstanding anything herein contained ;
 - (a) The liability of the Bank under this guarantee is restricted to the “B. G. Amount” and it will remain in force up to its Validity date specified above.
 - (b) The guarantee shall stand completely discharged and all rights of the BSNL under this Guarantee shall be extinguished if no claim or demand is made on us in writing on or before its validity date.
- 7. In case BSNL demands for any money under this bank guarantee, the same shall be paid through banker’s Cheque in favour of “AO (Cash), o/o CGMT,BSNL,Vijayawada” payable at Vijayawada.
- 8. The Bank guarantees that the below mentioned officer who have signed it on behalf of the Bank have authority to give this guarantee under its delegated power.

Place:

Date:

(Signature of the Bank Officer)
 Rubber stamp of the bank
 Authorized Power of Attorney Number:
 Name of the Bank officer:
 Designation:
 Complete Postal address of Bank:

 Telephone Numbers
 Fax numbers

Pro-forma of Performance Bank Guarantee (PBG)
(To be typed on non-judicial stamp paper of appropriate value)

Performance Bank Guarantee (PBG) dated:

Whereas<Contract awarding authority>(hereinafter referred to as BSNL)
Has issued an Award Letter no..... Dated .../.../20... for
awarding the work of Optical Fibre Cable Laying work to M/s.....
(hereafter referred to as “Contractor”) and the BSNL has asked them to submit a performance
bank guarantee, in favour of The CGMT,AP CO, BSNL BHAVAN,Vijayawada of Rs.
...../- (hereafter referred to as “BG. Amount”) valid up to .../.../20... hereinafter
referred to as “Validity Date”). Now at the request ofthe Contractor, We.....
Bank Branch having (Address) and Regd office
address as (Hereinafter called „the
Bank”) agreed to give this guarantee as hereinafter contained:

1. We, “the Bank” do hereby undertake and assure to the BSNL that if in the opinion of the BSNL,the Contractor has in any way failed to observe or perform the terms and conditions of the said agreement or has committed any breach of its obligations there-under, the Bank shall on demand and without any objection or demur pay to the BSNL the said sum limited to PBG Amount or such lesser amount as BSNL may demand without requiring BSNL to have recourse to any legal remedy that may be available to it to compel the Bank to pay the same.
2. Any such demand from the BSNL shall be conclusive as regards the liability of Contractor to pay to BSNL or as regards the amount payable by the Bank under this guarantee. The Bank shall not be entitled to withhold payment on the ground that the Contractor had disputed its liability to pay or has disputed the quantum of the amount or that any arbitration proceeding or legal proceeding is pending between Contractor and BSNL regarding the claim. Liability of the bank under this present being absolute and unequivocal.
3. We, the Bank further agree that the guarantee shall come into force from the date of its issue and shall remain in full force and effect up to its Validity date.
4. The Bank further agrees that the BSNL shall have the fullest liberty without the consent of the Bank and without affecting in any way the obligations hereunder to vary any of the terms and conditions of the said agreement or to extend the time for performance of the said agreement from any of the powers exercisable by BSNL against the Contractor and to forebear to enforce any of the terms and conditions relating to the said agreement and the Bank shallnot be relieved from its liability by reason of such failure or extension being granted to Contractor or through any forbearance, act or omission on the part of BSNL or any indulgenceby BSNL to Contractor or any other matter or thing whatsoever which under the law relating to sureties would but for this provision have the effect of relieving or discharging the guarantor.

I/727458/2024

5. Notwithstanding anything herein contained; (a) The liability of the Bank under this guarantee is restricted to the PBG Amount and it will remain in force up to its Validity date. (b) The guarantee shall stand completely discharged and all rights of the BSNL under this Guarantee shall be extinguished if no claim or demand is made on us in writing on or before its validity date. In case BSNL demands for any money under this bank guarantee, the same shall be paid through Banker's Cheque in favour of AO Cash, O/o CGMT, BSNL BHAVAN, Vijayawada-520004.

6. The Bank guarantees that the below mentioned officer who have signed it on behalf of the Bank have authority to give this guarantee under its delegated power.

Place:

Date:

(Signature of the Bank Officer)
Rubber stamp of the bank
Authorized Power of Attorney Number:
Name of the Bank officer:
Designation:
Complete Postal address of Bank:
Telephone Numbers
Fax numbers.....

SECTION - XI

PROFORMA OF AGREEMENT

The successful tenderer shall have to execute the following agreement;

NIT No: Dated:

LOI No: Dated:

This agreement made on this ___ day of (month)_____ (year)_____ between M/s _____ herein after called "The Contractor" (which expression shall unless excluded by or repugnant to the context, include its successors, heir, executors, administrative representative and assignee) of the one part & Chairman & Managing Director, BSNL through <Tender Issuing Authority> herein after referred to as BSNL, of other part.

Where as the contractor has offered to enter into contract with the BSNL for the execution of work of OFC laying (both Over Head & Under Ground) on behalf of BSNL using open trenching and Trenchless Technology (HDD) and other associated works of OF Cable on the terms and conditions herein contained and the rates approved by the BSNL (copy of Rates annexed) have been duly accepted and where as the necessary security deposits, as mentioned below, have been furnished in accordance with the provisions of the tender document and whereas no interest will be claimed on the security deposits.

- a) PBG No: for Rs. Issued by.....(Bank)
- b) Material Security BG No: for Rs. Issued by..... (Bank)

Now these presents witness and it is hereby agreed and declared by and between the parties to these presents as follows.

1) The contractor shall, during the period of this contract that is to say from.....
.....toor completion of work for Rs.
_____ (In words) _____ whichever is later until this contract shall be determined by such notice as is hereinafter mentioned, safely carryout, by means of labours employed at his own expenses and by means of tools, implements and equipment etc. to be supplied by him to his labour at his own expenses, all trenching and trenchless pipe laying, cable pulling, cable splicing, joint chamber preparation, fixing, painting and sign writing or route indicators and other associated works as described in tender documents (annexed to the agreement), when the Tender Issuing Authority or any other persons authorized by Tender Issuing Authority in that behalf require. It is understood by the contractor that the quantity of work mentioned on the schedule is likely to change as per actual requirements as demanded by exigencies of service.

2) The NIT (notice inviting tender), Bid documents (Qualifying and Financial), letter of intent, approved rates, annexed hereto and such other additional particulars, instructions, drawings,

1/727458/2024 work orders as may be found requisite to be given during execution of the work shall be deemed and taken to be an integral part of the contract and shall also be deemed to be included in the expression "The Agreement" or "The Contract" wherever herein used.

3) The contractor shall also supply the requisite number of workmen with means & materials as well as tools, appliances, machines, implements, vehicles for transportation, cartage etc. required for the proper execution of work within the time prescribed in the work orders.

4) The contractor hereby declares that nobody connected with or in the employment of the BSNL is not/shall not ever be admitted as partner in the contract.

5) The contractor shall abide by the terms and conditions, rules, guidelines, construction practices, safety precautions etc. stipulated in the tender document including any correspondence between the Contractor and the BSNL having bearing on execution of work and payments of work to be done under the contract.

In witness whereof the parties present herein set their respective hands and seals the day and year in _____

Above written:

Signed sealed &
Delivered by The above
named Contractor in
The presence of.

Witness:

- 1.
- 2.

Signed & Delivered on
behalf of BSNL by
the

Witness:

- 1.
- 2.

----- END OF SECTION XI -----

SECTION – XII (PART-A)
STANDARD SCHEDULE OF RATES FOR UG OFC LAYING

PREFIXED RATES FOR ALLIED OFC WORKS (Excluding GST)

S. No	Item Code	Description	Unit	Sched Rate per Unit in Rs.
		Laying OF PLB /HDPE PIPE 40-50mm dia coupled with sockets in the excavated cable trench as per the standard practices including loading, unloading, uncoiling and transportation from BSNL designated stores to site of work (Pipes, sockets will be supplied by BSNL at stores at no cost. Length of pipe laid is measured for payment)		
1	2PLB50/1	50mm dia 1 st Pipe	Per Mtr	5
2	2PLB40/1	40mm dia 1 st pipe	Per Mtr	5
3	2PLB50/2	50mm dia 2 nd Pipe	Per Mtr	5
4	2PLB40/2	40mm dia 2 nd Pipe	Per Mtr	5
5	2PLB50/A	50mm dia additional pipe	Per Mtr	5
6	2PLB40/A	40mm dia additional pipe	Per Mtr	5
	2PLB40/50/R	Laying of PLB /HDPE PIPE 40-50mm dia/green flexible pipe coupled with sockets in the Underground ducts, runways along with clamping/tying at customer premises (pipes,sockets will be supplied by BSNL at no cost. Length of pipe laid is measured for payment)		
7	2PLB40/50/R/1	1st Pipe	Per Mtr	8
8	2PLB40/50/R/2	2nd Pipe	Per Mtr	8
9	2PLB40/50/R/A	Additional pipe	Per Mtr	8
	2PLB40/50/F	Laying/leading-in of PLB /HDPE PIPE 40-50mm dia coupled with sockets /Green Flexible pipe along with clamping in customer premises along walls, partitions, in false ceiling etc (pipes, sockets will be supplied by BSNL at no cost. Length of pipe laid is measured for payment)		
10	2PLB40/50/R/1	1st Pipe	Per Mtr	11
11	2PLB40/50/R/2	2nd Pipe	Per Mtr	11
12	2PLB40/50/R/A	Additional pipe	Per Mtr	11

1/727458/2024	OFC PULLING (OF Cable & Accessories to be supplied by BSNL)			
13	Pulling of O.F Cable , and allied works (viz.. Replacing couplers and Bank filling in case of Manholes Sealing of PLB ends, refilling sand ,Refixing RCC cover and backfilling in case of joint chamber / Manhole). No. charges to be paid for opening of Manholes/Joint chamber.		Unit	Scheduled Rate per Unit in Rs.
14	3OFCP	24F/48F	Per Mtr	6
15	3OFCP/96	96F	Per Mtr	7.5
	Pulling of OFC Cable in underground ducts, <u>runways</u> as per the standard practices including allied works like replacing/refixing couplers (The rate includes loading,unloading,uncoiling and transportation of cables from BSNL designated stores to site of work.Length of cable is measured for payment).			
16	3OFCP/C	a) 24F to 96F	per metre	10
OFC BLOWING (OF Cable & Accessories to be supplied by BSNL)				
	Blowing of OFC Cable in cable trench as per the standard practices including DIT(Duct Integrity Test),and allied works like replacing/refixing couplers, Sealing of PLB ends, Fixing of Pre-cast RCC/DWC Chambers, filling of RCC/DWC Chambers with Clean sand, Placing of Pre cast RCC/DWC slabs on RCC/DWC Chambers and Back filling of the Jointing Pits as per the directions of Engineer in Charge. The rate includes loading, unloading, uncoiling and transportation of cables from BSNL designated stores to site of work. Length of cable is measured for payment).			
17	4OFBL1	24F/48F	Per Mtr	11
18	4OFBL2	96F	Per Mtr	13
19	4OFBL3	288F	Per Mtr	15
20	4OFBL4	OFC Blowing through DWC duct	Per Mtr	11
	Laying OF DWC Pipe Coupled with Sockets as per the standard practices including loading, unloading , uncoiling and transportation from BSNL designated stores to site of work (Pipes, sockets will be supplied by BSNL at stores at no cost. Length of pipe laid is measured for payment)		Unit	Scheduled Rate per Unit in Rs.
21	5DWCT1	DWC Pipe (Up to 100mm O.D), fixing, Handling & laying in trenches.	Per Mtr	5

22	5DWCT2	DWC Pipe (Above 100mm O.D), fixing, Handling & laying in trenches.	Per Mtr	5
23	5DWCT3	DWC pipe laying (Over bridge & Culverts) including clamping/fixing to the railing wall by drilling into RCC (2 Drills per each clamp) wherever required on the Culvert/Over bridge as per directions of Engineer In-charge	Per Mtr	70.25
Boring & RCC WORKS				
24	6DRC	Drilling works for leading in of PLB pipe of 40 mm size/Flexible Pipe or any other as per customer requirement and OF Cable into the customer premises to run the OF Cable up to the desired location..	Unit	
	a.	In RCC /concrete walls of any thickness, upto 40 mm size hole with core cutting machine	Per job	800
	b.	Brick masonry walls of any thickness, upto 40 mm size hole with core cutting machine	Per job	500
	c.	In wooden partitions, Glass partitions or any other partition material upto 40mm size hole	Per job	300
25	6CCW	Providing and laying in position cement concrete of specified grade in cable trench for protection of PLB Pipe /GI Pipe/DWC Pipe at low depth areas, Bridges, at Culvert crossings etc for low depth protection as per the directions of Engineer in charge. 1:2:4 (1 cement : 2 coarse sand : 4 graded stone aggregate 20 mm nominal size). PLB/GI/DWC Pipes will be supplied by BSNL at stores.	Per cubic metre	3850
JOINTING CHAMBER			Unit	Scheduled Rate per Unit in Rs.
26	7JTC	Supply of RCC Joint protection chamber of 1.2M outer diameter with precast RCC rings /collars and RCC top & base covers as per standard design and drawing with the following specifications i) Chamber consists of Precast RCC ring/collar of outer diameter 1.2M, 0.3M height and wall thickness of 50mm with concrete mix of 1 : 2: 4 (1 cement : 2 coarse sand (zone-III) : 4 graded stone aggregate 20 mm nominal size) with necessary reinforcement as per standard approved design& drawing. ii)Base/bottom plate is of precast RCC 1.2M dia 50mm thickness with mix of 1 : 2 : 4 (1 cement : 2 coarse sand (zone-III) : 4 graded stone aggregate 20 mm nominal size)with necessary reinforcement as per standard approved design& drawing. iii)Top plate consists of 2nos semi-circular plates each	Per chamber	2206

		made of precast RCC cover 1.2M dia and 50mm thickness with concrete mix of 1 : 2: 4 (1 cement : 2 coarse sand (zone-III) : 4 graded stone aggregate 20 mm nominal size) with necessary reinforcement as per standard approved design & drawing .		
ROUTE /JOINT INDICATOR				
27	8ORJF	Supply and fixing precast reinforced cement concrete 1:2:4 (1 cement : 2coarse sand : 4 graded stone aggregate 20mm nominal size) Route/Joint indicator with indicator dimensions (0.3m*0.12m*0.91m) & fixing in position in cement concrete (0.35*0.2*0.15) ,finishing smooth, and painting and sign writing etc., all as directed by Engineer in charge (Each indicator is counted for payment)	Per each	550
OTHER ALLIED WORKS				
28		63MM DWC DUCT	Per Mtr	47
28(a)		63 MM DWC Couplers	Per Each	22
28(b)		110 MM DWC Duct	Per Mtr	79
28(c)		110 MM DWC Couplers	Per each	40
28(d)	10STFP	Supply of Teflon flexible pipe of size 1" dia at work location including transportation	Per Mtr	50
29	10SFSD	Supply and Filling with stone dust in trenches, plinth, chambers, sides of foundations etc.at site including transportation in layers not exceeding 20cm in depth, consolidating each deposited layer by ramming and as per the directions of Engineer-in-charge. The cost includes all operations and nothing extra is payable	Cubic meter	1283
30	10SGIP	Supply of class B GI Pipe of 65 mm of 3.65mm thick @ 6.61 kg/m dia at work location including transportation wherever required as suggested by Engineer-in-charge	Runnin g meter	680

31	10RRBT	Road restoration work with bituminous macadam for semi grouting 50mm thick and premix carpet surfacing 25mm thick over the grouted surface (Total up to 75mm thick) including supply of asphalt etc., to evenly match the road, including consolidation and rolling.	Per Cu mtr	4950
32	10RRCC / DWC	Road restoration work with cement concrete 1:4:8 mix for thickness of 225mm including supply of concrete to evenly match the road.	Per Cu mtr	2310
33	10REDR	Cost of recovery of empty drums for 24F/48F	Per drum	100
34		Cost of recovery of empty drums for 96F/288F	Per drum	200
35	10GICL	Fabrication and supply of Galvanized clamps	Per kg	100
36	10CC	Providing CC protection (1:2:4) at site for encasing PLB pipe/GI Pipe in roads,bridges,crossings,culverts etc.,	Per Cu mtr	3850
CABLE SPLICING WORKS				
Splicing of all the fibers of OF cable laid at every joint within specified splicing loss range (≤ 0.02 dB) while testing with OTDR and making termination at the ends. All materials, Splicing Machine and labours except Joint Closer to be supplied by Bidder /Vendor). Joint Closures will be supplied by BSNL at stores.			Unit	Scheduled Rate per Unit in Rs.
38	11OFSPR/12	For 12 Fibers splicing– in Route	Per Joint	500
39	11OFSPTB / 12	For 12 Fibers splicing in Termination Box	Per Joint	500
40	11OFSPR/24	For 24 Fibers splicing in Route	Per Joint	1000
41	11OFSPTB /24	For 24 Fibers splicing in Termination Box	Per Joint	1000
42	11OF SPR/48	For 48 Fibres splicing in route	Per Joint	1500
43	11OFSPTB /48	For 48 Fibres splicing in termination box	Per Joint	1500
44	11OF SPR/96	For 96 Fibres splicing in route	Per Joint	2000
45	11OFSPTB /96	For 96 Fibres splicing in termination box	Per Joint	2000
46	11OFSPR/288	For 288 Fibres splicing in route	Per Joint	3000
47	11OFSPTB /288	For 288 Fibres splicing in termination box	Per Joint	3000

PART- B (OVER HEAD CABLE)

SCHEDULE OF RATES FOR OH OF CABLE LAYING WORKS IN A.P CIRCLE			
S.No	Description of item	Unit	SOR (In Rs)
1.1	Supply of Galvanized Steel tubular (round hollow tubes) pipes at work site of 6.00m height(Suspension pole) of 114.30mm outer diameter of thickness 4.50mm (Medium) including welding of bottom plate of size 0.25mX0.25m (Galvanization: Priming coat of approved steel primer and Galvanization of 100 micron for steel work).The cost includes the supply at work sites including the loading ,unloading and transportation.	1 No	7780
1.2	Supply of Galvanized Steel tubular (round hollow tubes) pipes at work site of 8.00m height(Tension pole) of 114.30mm outer diameter of thickness 4.50mm (Medium) including welding of bottom plate of size 0.25mX0.25m (Galvanization: Priming coat of approved steel primer and Galvanization of 100 micron for steel work).The cost includes the supply at work sites including the loading, unloading and transportation.	1 No	10370
2.1	Fixing of 6.00m Galvanized pipe in excavated trench of size 0.45mx0.45mX0.90m and providing & laying with cement concrete with 1:2:4 (1 cement : 2 coarse sand (zone-III) derived from natural sources : 4 graded stone aggregate 20 mm nominal size derived from natural sources.) in the excavated trench and also above ground level of size 045mx0.45mX0.20m. Cost includes of all operations involved for providing and fixing of pipe like excavation of earth work, providing & laying of cement concrete including centring and shuttering etc., and as per the directions of Engg-in-Charge.	1 No	1050

I/727458/2024

2.2	Fixing of 8.00m Galvanized pipe in excavated trench of size 0.45mX0.45mX1.2m and providing & laying with cement concrete with 1:2:4 (1 cement : 2 coarse sand (zone-III) derived from natural sources : 4 graded stone aggregate 20 mm nominal size derived from natural sources.) in the excavated trench and also above ground level of size 0.45mX0.45mX0.20m. Cost includes of all operations involved for providing and fixing of pipe like excavation of earth work, providing & laying of cement concrete including centring and shuttering etc., and as per the directions of Engg-in-Charge.	1 No	1305
3	O/H cable Accessories Supply & fittings (As per TEC/GR-TEC/GR/TX/OAF-001/03/ MAR-17(Type-II) with subsequent amendment if any).		
3.1	Terminating pole Assembly Fittings- To be used at tension/terminating poles(dead end poles)or poles where splices are located and the poles where the overhead alignment takes a turn(angle exceeding more than 15 degrees)	Unit	SOR (In Rs)
	Supply of complete set of Terminating pole assembly fittings that include (i) J-Shaped tension hook–2nos. (ii) Turn Buckle–2nos. (iii) Extension Link–2nos. iv) Clevis Thimble–2nos. v) Protective Helix (T)–2nos. vi) Terminating Helix–2nos. vii) Jumper Cable Clamp–1no. viii) Pole Mounted Stay Clamp (Tubular)–1no.	1 Set	2000
3.2	Suspension pole Assembly fittings Type I-For intermediate poles(ADSS/Conventional OFC cable)		
	Supply of suspension pole assembly fittings that include (i) Pole Mounted Stay Clamp (Tubular)–1no. (ii) Twisted Eye Link- 1no. (iii) Protective Helix(S)-1no. (iv) Armour Grip (AGS) Helix-1no. (v) Suspension Clipper with ElastomerPad-1pair (vi) Spiral Vibration Damper(SVD)-2nos	1 Set	1250

I/727458/2024

3.3	Suspension pole Assembly fittings Type II-For intermediate poles (ADSS/Conventional OFC cable)		
	Supply of suspension pole assembly fittings that include (a) Universal pole bracket (with SS Strip & buckle on pole)-1no. (b) Clevis Thimble- 1no. (c)Suspension Helix (GI steel or Aluminum)-1no. (f) Spiral Vibration Damper(SVD)-2nos	1 Set	660
4	Laying of OF Cable through overhead method including the assembly and fitting of accessories to the GI poles		
4.1	4 F	per meter	7
4.2	12F (ADSS)	per meter	12
4.3	24F/48F (ADSS)	per meter	15
4.4	Laying of OF Cable through overhead conventional method with the use of existing third Party structures like Electrical poles (only for 4F)	per meter	4
5	Supply of Binding wire 75 Lbs at work site(optional)	per KG	70
		Unit	SOR (In Rs)
6	Supply of 1" dia Green flexible pipe at work site	per meter	50
7	Recovery of existing Over Head OFC cable	per meter	
7.1	(a) 4F	per meter	4
7.2	(b) 24F/48F	per meter	7
		Unit	SOR (in Rs)
8	Digging charges for tracing joint location of U/G cables whenever required to tap existing BSNL PoP/Cable end(Jointing kits will be supplied by BSNL)(Trench Specs. Refer to U/G SOR)	per meter	218.57

	Jointing of OF Cable (Based on field requirement)	Unit	SOR (in Rs)
9	a) for 2F/4F/6F	per joint	250
	b) for 12F	per joint	500
	c) for 24F	per joint	1000
	d) for 48F	per joint	1500
	e) Cross capacity jointing (low capacity cable to higher based on necessity).The low capacity cable splicing charges applicable.	per joint	Based on no. of fibres spliced
10	Digging & opening of of existing joint chambers for operating the joint including splicing & reinstatement of the chamber to the original position.	per unit	
10.1	2F/4F/6F		670.00
10.2	12F		920.00
10.3	24F		1420.00
10.4	48F		1920.00
10.5	96F		2420.00
10.6	288F		3420.00
Note:	In case of Suspension pole assembly, either S.No 3.2 or 3.3 may be adopted as per the field requirement		

Note: - 1. The above Schedule of Rates is for the OFC cable laying works to be carried out as per the description of various items as specified in the Engineering Instructions and Construction Specifications for OF cable laying works issued by BSNL.

Note- 2. Above Standard Schedule of Rates are inclusive of all taxes and levies but exclusive of GST. GST shall be paid extra as applicable to the GST registered contractors.

----- END OF SECTION XII -----

SECTION XIII**OF CABLE CONSTRUCTION SPECIFICATION MANUAL**

The guidelines in the form of Engineering Instructions (E.Is.) on Construction Practices of Optical Fibre Cables for both Under Ground/Over Head cables are issued by T & D wing of the Department, from time to time. However, the present practices are summarized here under, from the point of view of describing scope of work under various items of work. This document will need revision as and when practices undergo any revision.

1. General

The Optical Fibre Cable is planned considering the following objectives of the scheme:

- i) Minimum possible route length vis-a-vis route having maximum number of towns with potential telecom growth.
- ii) Linking of small exchanges off main road by leading in O.F.C. vis-a-vis routing the main cable itself via such exchanges.

After deciding above mentioned issues, a detailed measurement of lengths of cable route along with details of rail/road crossings, culverts, causeways, etc. may be recorded in the detailed survey register. The probable locations of joints, terminations and re-generators may also be decided and marked on the route map.

On the basis of surveys, general permission from road and rail authorities for laying the Optical Fibre Cable along the decided routes and permission for rail / road crossings will have to be obtained. Generally, O.F.C. is laid straight as far as possible along the road near the boundaries, away from the burrow pits. The O.F.C. is laid along the roads at a minimum distance of 15 metres from the center line of the road or in accordance with the permission from the concerned road authorities in view of their road widening plan. As the O.F.C. carries high capacity traffic and is planned for 40 years of life, it is imperative that the cable is laid after obtaining due permission from all the concerned authorities to avoid any damage/shifting at a later stage and also disruption of services/ revenue loss.

In special cases, where it may be necessary to avoid burrow pits or low lying areas, the cable may be run underneath the shoulders at a distance of 0.6 metre from the outer edge of the road embankment provided the same is located at least 4.5 metres away from centerline of road and 1.2 metre below the road surface.

The Optical Fibre Cable is laid through PLB Pipes/Coils buried at a nominal depth of 165cms.

The steps involved in OF Cable construction are as under:

- i) Excavation of trench upto a nominal depth as specified, according to construction specifications along National/State Highways/other roads and also in city limits as mentioned in the notice inviting tender.
- ii) Laying of PLB pipes/coils coupled by PLB sockets in excavated trenches, on bridges and culverts, drawing of 6 mm polypropylene para pro rope (P.P. rope) through the PLB pipes/coils as per Construction Specifications and sealing of PLB pipe ends at every manhole by PLB end caps of suitable size.

I/727458/2024

iii) Providing of mechanical protection by R.C.C. Pipes/GI pipes and/or concreting/chambering according to construction specifications, wherever required.

iv) Fixing of GI pipes/troughs with clamps at culverts/bridges and/or chambering or concreting of G.I. Pipes/troughs, whenever necessary.

v) Back filling and dressing of the excavated trenches according to construction specifications. Digging of pits 1 metre towards jungle side at every manhole chamber to a depth of 60 cms, fixing of route indicator, concreting and back filling of pits. Painting of route indicators with yellow colour and sign writing denoting route indicator number as per construction specifications.

vi) Documentation.

The documentation, consisting of the following shall be prepared exchange to exchange for intraBA OFC links and for each section in case of inter SSA/National long distance routes.

a) **Route Index Diagrams – General:** This diagram shall consist of Cable Route Details on Geographical Map drawn to scale the prominent land marks and alignment of cable with reference to road. This shall be prepared on A-3 sheets of 80 GSM.

b) **Route Index Diagrams – Profile:** These diagrams will contain:

- a. Make and size of the cable.
- b. Offset of cable from center of the road at every 10 meters
- c. Depth profile of Cable at every 10 meters
- d. Details of protection with type of protection depicted on it
- e. Location of culvert and bridges with their lengths and scheme of laying of PLB pipe/PLB Blowing Type/Pre-installed ropes thereon.
- f. Important landmarks to facilitate locating the cable in future
- g. Location of joints and pulling manholes.

These diagrams shall be prepared on **A-4 sheets** of 80 GMS. On one sheet profile of maximum 400 meters shall be given to ensure clarity.

c) **Joint location Diagram:** This diagram will show:

- a. Geographical location of all the joints.
- b. Depth of Joint Chamber covers from ground level
- c. Type of chamber (Brick/Pre-cast)
- d. Length of O.F. Cable kept inside the joint chamber from either direction.

This shall be prepared on **A-4 sheets** of 80 GSM. All the diagrams (i), (ii) & (iii) shall bear the signatures of the contractor, the Engineer-in-charge as a proof of accuracy of the details. The diagrams shall be bound in A-4 size book with cover. The cover sheets shall be of 110 GSM and laminated. The front cover shall have the following details.

1. Name of the SSA/Project Organization.
2. Name of the OFC Link
3. Name of the Contractor
4. Date of commencement of work
5. Date of completion of work

For each route/section 6 sets of above-mentioned document shall be submitted.

I/727458/2024

2. PLB/ROPE Materials used:

PLB PIPE/COILS

PLB Socket: For coupling PLB Pipes/coils

PP Rope: 6mm PP rope is drawn through the PLB pipes / coils and safely tied to the end caps at either ends with hooks to facilitate pulling of the OF cables at a later stage

PLB End Caps: For pulling the cable through the pipes, it is necessary to have suitable manholes at every 200M length and also at bends and corners suitably located. The pipes are laid for 200M or less at a time for the distance between two manholes. The ends of the PLB pipes/coils are closed with PLB End Caps. A suitable arrangement should be provided in the EndCap to tie PP Rope.

MATERIALS FOR MECHANICAL PROTECTION

For lesser depths requiring mechanical protection as per specifications and in built up areas, in towns and cities falling within the municipal limits, suitable mechanical protection is provided to PLB pipes/coils using RCC full/half round pipes or GI pipes or concreting of size 25 cms x 25 cms reinforced with MS weld mesh or a combination of any of these as per the instructions of the SDE-in-charge of the work as per instructions of the Engineer-in-Charge.

G.I. PIPES: Whenever protection by G.I. pipe is provided, it is preferable to use PLB coils. As space on parapet wall on Bridges/culverts is limited, 40mm GI pipes may be used with 32 mm PLB coil drawn inside.

M.S. Weld Mesh: The PLB pipes can also be protected by embedding it in concrete of size of 25 cms x 25 cms reinforced with MS weld mesh.

The strength of RCC/CC is dependent on proper curing, therefore, it is imperative that water content of CC/RCC mix does not drain out into the surrounding soil. In order to ensure this, the RCC/CC work should be carried out by covering all the sides by yellow PVC sheets of weight of not less than 1 kg per 8 sq. m. to avoid seepage of water into the soil.

RUBBER BUSH: To prevent entry of rodents into PLB pipes, the ends of PLB pipes are sealed at every manhole and joint using rodent resistant hard rubber bush (cap), so that it should be able to prevent the entry of insects, rodents, mud, and rainwater into the PLB pipe/Coil.

ROUTE INDICATOR: The route indicators are co-located with each manhole. In addition, route indicators are also to be placed where route changes direction like road crossings etc. The route indicators made of pre-cast RCC should have the dimensions: Base, Top, Height & the word 'BSNL OFC' should be engraved on the route indicators. (See **Route Indicator Diagram/figure 'A' for details**). The route indicators are painted yellow and the same are placed at 2 ft. away from the center of the trench towards jungle side. The engraved word 'BSNL OFC' should be painted in white, on route indicators. Numbering of route indicators should be done in white paint. The numbering scheme for route indicators will be Joint No./Route Indicator No. for that joint. For example, 2/6 marking on a route indicator means 6th route indicator after 2nd joint. Enamel paints of reputed brand should be used for painting and sign writing of route as well joint indicators.

1/727458/2024
JOINT CHAMBER

The joint chamber is provided at every joint normally at a distance of 2 Kms to keep the O.F.C. joint well protected and also to keep extra length of cable which may be required in the event of faults at a later date. The joint chambers are made at site using bricks and mortar or are of pre-cast RCC type.

Supply and fixing of Pre-fabricated RCC Closure as Joint Chamber:

For supplying RCC Ring, First, a RCC ring closure of size 1.2m \square (dia) x 0.3m depth and rim thickness 50mm made of standard 1:2:4 concrete mix. It should have a split (with two halves) RCC cover of thickness 50mm made of cement concrete mix of 1:2:4 (1: cement, 2: coarse sand, 4 stone aggregate mm nominal size reinforced with MS fabric 75 x 75 mm mesh of weight not less than 7.75 Kg per sq. meter having galvanized iron handles for each half to facilitate easy lifting, to be used as joint chamber. The word 'OFC' should be engraved on each half of the cover. The joint chamber should be so designed that PLB pipe/PLB Blowing Type/Pre-installed rope ends remain protruding minimum 5 cms inside the chamber. The PLB pipes should be embedded within the chamber in such a way that PLB pipe remains free from the weight of the construction. The joint chamber should be plastered on all internal surfaces and top edges with cement mortar of 1:3 (1: cement, 3: coarse sand) with a floating coat of complete cement as per standard. The joint chamber is to be filled with clean sand before closing.

In Golden Quadrilateral & East West Corridor routes (every 10 Km) :

For fixing Pre-cast RCC chamber, first a pit of size 1.5 m x 1.5 m x 1.65 m depth is required to be dug. Pre-cast RCC chamber consists of three parts (i) round base plate in two halves of 140 cm dia and 5 cm thickness (ii) full round RCC joint chamber with diameter of 120 cm and height of 100 cm and thickness of 5 cm (iii) round top cover will be in two halves with diameter of 140 cm and thickness of 5 cm having one handle for each half in centre and word 'BSNL OFC' engraved on it. After fixing the pre-cast RCC joint chamber, the joint chamber is filled with clean sand before closing. Lastly, back filling of joint chamber pit with excavated soil is carried out.

Important Note: The contractor has to supply RCC chambers as per the BSNL specifications.

CABLE PULLING AND JOINTING/SPLICING:**CABLE PULLING:**

Manholes marked during PLB pipe Type/Pre-installed ropes laying of approx. size of 3m length x 1.0m width x 1.65m depth shall be excavated for pulling the cables. There may be situations where additional manholes are required to be excavated for some reasons, to facilitate smooth pulling of cable. Excavation of additional manholes will be carried out, without any extra cost. De-watering of the manholes, if required, will be carried out without any extra cost. Dewatering/ De-gasification of the ducts, if required, will be carried out without any extra cost. The existing 6mm PP rope shall be replaced by with PP rope of 8mm dia between the two consecutive manholes. This is to ensure that the PLB pipes Type/Pre-installed ropes are cleaned for pulling the cable without exerting undue tension on the OF cable. While cleaning, excessive pressure should not be put as this may result in breaking of P.P. rope and thus requiring opening of additional manholes. However, in case the cleaning rope gets stuck up during pulling, the location of clogging of PLB Pipe Type/Pre-installed ropes should be measured and located accurately. The trench at that location should be opened and the PLB Pipe Type/Pre-installed ropes should be cleaned properly or if not

possible, it should be changed by a clean new PLB Pipe Type/Pre-installed ropes to facilitate easy cable pulling at a later stage without any breakage. If clogging of PLB Pipe Type/Pre-installed ropes is in the location where the pipes are protected either by RCC Pipe Type/Pre-installed ropes or by concreting and the protection is broken for cleaning/changing the PLB Pipe, the protection thus removed should be brought back to normal by the contractor without any extra cost. However, PLB Pipes Type/Pre- install edropes, RCC Pipes required for this purpose will be supplied by the BSNL.

The tenderer should arrange to lift the blowing machine to the work spot at his own cost. Cable shall be blown to the required length without intermittent cutting of PLB pipes except at the manholes provided

3. EXCAVATION OF TRENCHES

i) Trenching

Location and Alignment of the Trench: In city areas, the trench will normally follow the foot- path of the road except where it may have to come to the edge of the carriage way when cutting across road with specific permissions from the concerned authorities maintaining the road (such permissions shall be obtained by the department). Outside the city limits the trench will normally follow the boundary of the roadside land. However, where the road sideland is full of burrow pits or afforestation or when the cable has to cross culverts/bridges or streams, the trench may come closer to the road edge or in some cases, over the embankment or shoulder of the Road (Permissions for such deviations for cutting the embankment as well as shoulder of the road shall be obtained by the contractor on behalf of BSNL).

The alignment of the trench will be decided by a responsible departmental official, not below the rank of a Junior Telecom Officer. Once the alignment is marked, no deviation from the alignment is permissible except with the approval of Engineer-in-charge. While marking the alignment only the center line will be marked and the Contractor shall set out all other work to ensure that, the excavated trench is as straight as possible. The Contractor shall provide all necessary assistance and labour, at his own cost for marking the alignment. Contractor shall remove all bushes, undergrowth, stumps, rocks and other obstacles to facilitate marking the center line without any extra charges. It is to be ensured that minimum amount of bushes and shrubs shall be removed to clear the way and the contractor shall give all consideration to the preservation of the trees.

ii) **Line-Up:** The line-up of the trench must be such that PLB pipe(s) shall be laid in a straight line except at locations where it has to necessarily take a bend because of change in the alignment or gradient of the trench, subject to the restrictions mentioned elsewhere.

iii) **Method of Excavation:** In city limits as well as in built up areas, the contractor shall resort to use of manual labour only to ensure no damage is caused to any underground or surface installations belonging to other public utility services and/or private parties. However, along the Highways and cross country, there shall be no objection to the Contractor resorting to mechanical means of excavation, provided that no underground installations exist in the path of excavation, if any, are damaged.

There shall be no objection to resort to horizontal boring to bore a hole of required size and to push through G.I. Pipe (65mm/40mm dia) through horizontal bore at road crossing or rail crossing or small hillocks etc.

All excavation operations shall include excavation and 'getting out'. 'Getting out' shall include throwing the excavated materials at a distance of at least one metre or half the depth of excavation, whichever is more, clear off the edge of excavation. In all other cases 'getting out' shall include depositing the excavated materials as specified.

In Rocky strata excavation shall be carried out by use of electro mechanical means like breakers or by blasting wherever permissible with express permission from the competent authority. If blasting

operations are prohibited or not practicable, excavation in hard rock shall be done by authorized.

Trenching shall as far as possible be kept ahead of the laying of pipes. Contractor shall exercise due care that the soil from trenching intended to be loose for back filling is not mixed with loose debris. While trenching, the Contractor should not cause damage to any underground installations belonging to other agencies and any damage caused should be made good at his own cost and expense.

The contractor to prevent any accident to pedestrians or vehicles shall provide necessary barricades, night lamps, warning boards and required watchman. While carrying out the blasting operations, the contractor shall ensure adequate safety by cautioning the vehicular and other traffic. The contractor shall employ sufficient man-power for this with caution boards, flags, sign writings etc.

The contractor should provide sufficient width at the trench at all such places, where it is likely to cave in due to soil conditions without any extra payment. A free clearance of minimum 15 cms. should be maintained above or below any existing underground installations. No extra payment will be made towards this.

In order to prevent damage to PLB pipes over a period of time, due to the growth of trees, roots, bushes, etc. the contractor shall cut them when encountered in the path of alignment of trench without any additional charges.

In large burrow pits, excavation may be required to be carried out for more than 165 cms in depth to keep gradient of bed less than 15 degrees with horizontal. If not possible as stated above, alignment of trench shall be changed to avoid burrow pit completely.

iv) **Depth and Size of the Trench :** For normal & hard soil for all areas including ordinary & hard rock for all areas minimum depth shall be 165 cms shall be for penalty. For ordinary & hard rock minimum depth shall be 135 cms shall be followed for penalty. For Hilly terrain, minimum depth shall be 90 cms shall be followed for penalty. However, Engineer-in-charge in exceptional cases due to adverse site conditions encountered, may allow to lay PLB Pipes at a lesser depth with additional protection. In all cases, the slope of the trench shall not be less than 15 degrees with the horizontal surface. The width of the trench shall normally be 45 cms. at the top and 30 cms. at the bottom. In case, additional pipes (PLB/GI/RCC Pipes) are to be laid in some stretches, the same shall be accommodated in this normal size trench. When trenches are excavated in slopes, uneven ground, inclined portion, the lower edge shall be treated, as top surface of land and depth of trench will be measured accordingly. In certain locations, such as uneven ground, hilly areas and all other places, due to any reason whatsoever it can be ordered to excavate beyond standard depth of 165 cms to keep the bed of the trench as smooth as possible. Near the culverts, both ends of the culverts shall be excavated more than 165 cms. to keep the gradient less than 15 degree with horizontal. In case where depth beyond specified depth is necessary it shall be clearly indicated in the technical specification of bid documents and of each work order. No extra payment shall be made for such extra depth.

If excavation is not possible to the minimum depth of 165 cms., as detailed above, full facts shall be brought to the notice of the Engineer-in-charge in writing giving details of location and reason for not being able to excavate that particular portion to the minimum depth. The competent authority shall grant approval in writing under genuine circumstances. The decision of the competent authority shall be final and binding on the contractor.

v) **Dewatering:** The Contractor shall be responsible for all necessary arrangements to remove or pump out water from trench. The Contractor should survey the soil conditions encountered in the section and make his own assessment about dewatering arrangements that may be necessary. No extra payment shall be admissible for this.

vi) **Wetting:** Wherever the soil is hard due to dry weather conditions, if watering is to be done for wetting the soil to make it loose, the same shall be done by the contractor. No extra payment shall be admissible for this.

vii) **Blasting:** For **excavation in hard rock**, where blasting operations are considered necessary, the contractor shall obtain approval of the Engineer-in-Charge in writing for resorting to blasting operations. The contractor shall obtain license from the competent authority for undertaking blasting work as well as for obtaining and storing the explosive as per the Explosive Act, 1884 as amended up to date and the explosive Rules, 1983. The contractor shall purchase the explosives fuses, detonators, etc. only from a licensed dealer. Transportation and storage of explosive at site shall conform to the aforesaid Explosive Act and Explosive Rules. The contractor shall be responsible for the safe custody and proper accounting of the explosive materials. Fuses and detonators shall be stored separately and away from the explosives. The Engineer-in-Charge or his authorized representative shall have the right to check the contractor's store and account of explosives. The contractor shall provide necessary facilities for this. The contractor shall be responsible for any damage arising out of accident to workmen, public or property due to storage, transportation and use of explosive during blasting operation. Blasting operations shall be carried out under the supervision of a responsible authorized agent of the contractor (referred subsequently as agent only), during specified hours as approved in writing by the Engineer-in-Charge. The agent shall be conversant with the rules of blasting. All procedures and safety precautions for the use of explosives drilling and loading of explosives before and after shot firing and disposal of explosives shall be taken by the contractor as detailed in **IS:4081** safety code for blasting and related drilling operation.

viii) **Trenching Near Culverts/Bridges :** The PLB pipes shall be laid in the bed of culvert at the depth not less than 165 cms protected by G.I. pipes/ DWC/ RCC and concreting as decided by Engineer-in-Charge.

Both ends of culverts shall be excavated more than 165 cms in depth to keep the gradient of not less than 15 degree with horizontal. The bed of trench should be as smooth as possible.

While carrying out the work on bridges and culverts, adequate arrangement for cautioning the traffic by way of caution boards during day time and danger lights at night shall be provided.

In case of small bridges and culverts, where there is a likelihood of their subsequent expansion and authorized, the cable should be laid with some curve on both sides of the culvert or the bridge to make some extra length available for re-adjustment of the cable at the time of reconstruction of culvert or the bridge.

4. LAYING OF H.D.P.E. PIPES / COILS:

After the trench is excavated to the specified depth, the bottom of the trench has to be cleared of all stones or pieces of rock and leveled up properly. A layer of soft soil/or sand (in case the excavated material contains sharp pieces of rock/stones) of not less than 5 cms is required for leveling the trench to ensure that the cable when laid will follow a straight alignment. Adequate care shall be exercised while laying so that the OF cables are not put to undue tension/pressure after being laid as this may adversely affect the optical characteristics of cables with passage of time.

The contractor shall ensure that trenching and pipe laying activities are continuous, without leaving patches or portions incomplete in between. In case intermediate patches are left, measurement of the completed portions will be taken only after work in such leftover patches are also completed in all respects.

Preparatory to aligning the pipe for jointing, each length of the PLB pipe shall be thoroughly cleaned to remove all sand, dust or any other debris that may clog, disturb or damage the optical Fibre cable when it is pulled at a later stage. The ends of each pipe and inside of each PLB socket shall be thoroughly cleaned of any dirt or other foreign materials.

After the trench is cleaned the PLB Pipes/Coil shall be laid in the cleaned trench, jointed with "O" ring type PLB Sockets & 6 mm PP rope should be drawn through the PLB Pipes at the time of laying the pipes to facilitate cable pulling at a later stage. At every manhole approximately at every 200m or at bends or turns the pp rope will be tied to the PLB end caps used for sealing the PLB pipes, to avoid entry

of rodents/mud etc.

At the end of each day work, the open ends of the pipes sections shall be tightly closed with end caps to prevent the entry of dirt/mud, water or any foreign matter into PLB pipes until the work is resumed.

In City, Town, Urban area falling within Municipal/Corporation limits, the PLB Pipes shall be laid with protection using RCC/DWC/G.I. Pipes/Concreting reinforced with weld mesh. Moreover, in cross country routes, if depth is less than 1.2 metres, protection by using RCC/DWC/G.I. Pipe/Concreting reinforced with weld mesh shall be provided. Engineer-in-charge shall decide about such stretches and type of protection to be provided in view of the site requirements. Normally 100mm RCC/DWC Pipes shall be used for protecting PLB Pipe but if more than one PLB Pipe is to be laid and protected, RCC/DWC Pipe of suitable size to accommodate the required number of PLB Pipes shall be used.

The PLB Pipes shall be laid in RCC Full Round spun Pipes/DWC/GI pipes as required at road crossings. The RCC pipes/GI pipes shall extend at least 3 metres on either side of the road at road crossings. At road crossings, extra GI/PLB Pipes may be laid as per the direction of the Engineer-in-charge. On Rail bridges and crossings, the PLB Pipes shall be encased in suitable cast iron as prescribed by the Railway Authorities.

Whenever RCC pipes are used for protection, the gaps between the RCC collars and the RCC pipes shall be sealed using cement mortar 1:3 (1:53 grade cement of reputed brand, 3: fines and without impurities) to bar entry of rodents. Every third collar of RCC pipes (Normally of 2 metres length) and also both ends of RCC Pipes will be embedded in a concrete block of size 40 cms. (L) x 40 cms (W) x 25 cms (H) of 1:2:4 cement concrete mix (1:53 grade cement of reputed brand, 2: coarse sand, 3: stone aggregate of nominal size of 20mm) so that the alignment of RCC pipes remain firm and intact and to avoid entry of rodents.

Wherever GI Pipes are used, special care should be taken to ensure that G.I. Pipes are coupled properly with the sockets so as to avoid damage to PLB Pipe and eventually the OF Cable in the event of pressure coming on the joint and G.I. Pipe joint giving its way. Rubber bushes shall be used at either ends of the GI pipes to protect PLB Pipe. Both the ends of G.I Pipe will be embedded in a concrete block of size 40 cms (L) x 40 cms (W) x 25 cms (H) of 1:2:4 cement concrete mix (1:53) grade cement of reputed brand, 2: coarse sand, 3: stone aggregate of nominal size of 20mm) so that the alignment of G.I. Pipes remain firm and intact and to avoid entry of rodents.

In case of protection by concreting at site, the nominal dimension of concreting shall be 250mm x 250mm section. Cement Concrete Mixture used shall be of 1:2:4 composition

i.e. 1: 53 grade Cement of a reputed company, 2 : Coarse Sand, 4 : Graded Coarse Stone aggregate of 20mm nominal size, reinforced with MS weld mesh. As the RCC is cast at site, it is imperative to ensure that special care is taken to see that proper curing arrangements are made with adequate supply of water. The contractor shall invariably use mechanical mixer at site for providing RCC protection to ensure consistency of the mix.

For carrying out concreting work in trenches, yellow PVC sheets of width not less than 1.0M and of weight not less than 1 kg. per 8 sq. metres shall be spread and nailed on sides of the trench to form trapezoidal section for concreting in the cleaned trench, to avoid seepage of water into the soil. A bed of cement concrete mixture of appropriate width and 75 mm thickness shall be laid on the PVC sheet, before laying PLB pipes. The PLB pipes shall then be laid above this bed of concrete. After laying the PLB pipes, MS weld mesh should be wrapped around and tied and concrete mix is to be poured to form the cross sectional dimensions as instructed by the Engineer-in-charge. The strength of RCC is dependent on proper curing, therefore, it is imperative that water content of RCC mix does not drain out into the surrounding soil. Portions where cement concreting have been carried out shall be cured with sufficient amount of water for reasonable time to harden the surface.

After curing, refilling of the balance depth of the trench has to be carried out with excavated soil. The PLB pipes/RCC/GI pipes shall be laid only in trenches accepted by Engineer-in-charge or his representative. The Contractor shall exercise due care to ensure that the PLB pipes are not subjected to any damage strain.

Water present in the trench at the time of laying the PLB Pipes shall be pumped out by the contractor before laying the pipes in the trench to ensure that no mud or water gets into the pipes, thus choking it. In case of nallahs, which are dry for nine months in a year, the PLB Pipes shall be laid inside the RCC Pipes/ or GI Pipes and concrete laid at a minimum depth of 165 cms., as instructed by the Engineer-in-charge. The mechanical protection shall extend at least 5 metres beyond the bed of nallah on either side. Notwithstanding anything contained in clauses referred above, the Engineer-in-charge may order, based on special site requirements, that the PLB Pipes may be encased in reinforced cement concrete, as detailed, *ibid*.

While laying the pipes, a gap of 2M is kept at convenient locations approx. 200m apart and at the bends and turns, which will be used as manholes during OF cable pulling. Ends of the PLB pipes at the manholes shall be sealed using PLB end caps after tying the PP rope to the end caps to avoid choking of the pipes. In a similar manner, manholes shall be kept while approaching bridges, road crossings etc., as instructed by the Engineer-in-charge. The location of the manholes will be decided by the Engineer-in-charge.

5. Laying Protection Pipes on Bridges and Culverts :

In case trenching and pipe laying is not possible in the beds of the culverts, the pipes shall be laid over the culverts/bridges after getting due permission from the competent authority. Of late the bridge construction authorities are providing ducts below the footpaths on the bridges for various services. The telecom officers need to maintain good liaison with the concerned authority to get one side of the duct allotted for Telecom Cables. In such ducts,

G.I. Pipes can be coupled and laid for pulling the cables. It would be pertinent to mention here that close liaison with bridge construction authorities would be of immense advantage in ensuring provision of ducts on one or both the sides of the bridges as per future requirements. However, for laying cables on existing bridges, where duct arrangement does not exist, one of the following methods may be adopted.

Normally in the Bridges/Culverts, where there are no ducts and where the cushion on the top of the Arch is 50 cm to 100 cm or more, G.I. Pipe (Carrying PLB pipe and cable) may be buried on the top of the Arch adjoining the parapet wall, by digging close to the wheel guards. Every precaution shall be taken to see that no damage occurs to the arch of the culvert. After burying the GI pipe, the excavated surface on the arch shall be restored. Where the thickness of the Arch is less than 50 cms, the pipe must be buried under the wheel guard masonry and the wheel guard rebuilt.

If neither of the two methods is possible, the G.I. Pipes/GI Troughs/DWC Pipes must be clamped outside the parapet wall with the clamps. If necessary, the pipe may be taken through the parapet wall at the ends where the wall diverges away from the road.

In case where the methods explained in clauses referred above are not possible, the G.I. Pipes/GI Troughs/DWC Pipes can be fixed on the top of the road curb close to the inside face of the parapet wall by means of clamps, using raw plugs and wood screws or small diameter bolts, without damaging the concrete and limiting the external diameter of the bolts to 7.5 mm. The permission for carrying out this work will be obtained from the Road Authorities by the contractor. Methods cited in above clauses should be carried out under close supervision of Road authorities.

The surface to be concreted should be thoroughly cleaned and leveled before concreting. At both ends of the Bridges/Culverts, where the GI Pipes/GI Troughs slope down and get buried, the concreting should be extended to ensure that no portion of the GI Pipes/GI Troughs is exposed as ordered by the Engineer-in-charge to protect the Pipe/Trough from any possible damage externally caused. Where white wash/colour wash is existing on the Bridges/Culverts, the same should also be carried out on the concreted portion to ensure uniformity.

6. Back Filling and Dressing of the Trench :

The earth used for filling shall be free from all roots, grass, shrubs, vegetation, trees, saplings and rubbish. Provided that the PLB Pipes have been properly laid in the trench at the specified depth, the back-filling operation shall follow as closely as practicable. The back-filling operation shall be performed in such a manner so as to provide firm support under and above the pipes and to avoid bend or deformation of the PLB pipes when the PLB pipes get loaded with the back filled earth.

At locations where the back filled materials contains stones/sharp objects which may cause injury to the PLB pipes and where the excavated or rock fragments are intended to refill the trench in whole or in part, the trench should be initially filled, with a layer of ordinary soil or de-rocked loose earth of not less than 10 cms above the pipes.

Back filling on public, private roads, railway crossings, footpaths in city areas shall be performed immediately after laying the PLB pipes. Back filling at such locations shall be thoroughly rammed, so as to ensure original condition and made safe for traffic. All excess soil/material left out on road/footpath/railway crossing shall be removed by contractor. However, along the highways and cross-country, the dug-up material left out should be kept asheap above the trench while refilling.

In city limits, no part of the trench should be kept open for more than 50 metres length at any time and in all places where excavation has been done, no part of the trench should be kept open overnight to prevent any mishap or accident in darkness.

7 MICRO TUNNELING

GENERAL WORK DESCRIPTION

Laying of PLB pipe of different types and sizes in general, including some or all of the following activities:-

Horizontal boring and laying the PLB pipe through it:

Horizontal boring and PLB pipe laying through it along road and under railway/ road/ canal/ streams crossing in all type of soil at suitable depth including all civil works. Supply of all tested tools and tackles other required equipment and consumables, labour etc. and making all such necessary arrangements are under vendor's scope. Total job has to be completed within time schedule mentioned in work order. The work is specified under two major heads.

- a) Laying along the road.
- b) Road/ Rail/ canal crossing (road crossing means crossing a road of minimum width of 8 mtr.)

Under each head there will be again three different sizes of boring :

- a) Boring of single pipe.
- b) Boring from two pipes to four pipes.

I/727458/2024

c) Boring more than four pipes.

The PLB pipe will be pulled through the horizontal bore with insertion of nylon rope provided by the department. Balloon (25mm. dia and 45mm length) test both ways is to be carried out by the bidder including the rope insertion if necessary for each pipe line. Duct integration test is to be carried out for each pipe in case of without rope pipes.

SPECIFICATION FOR PLB PIPE LAYING BY MICRO TUNNELING

1. In this system of cable laying following job specification should be maintained:

- (i) Guided boring / drilling technology is to be used. Mechanical mores are not permitted
 - a. Radio or any other detection system should be used for avoiding damage to existing underground utilities i.e. electric supply, water pipe lines, telecom copper cables and optical fibre cables, gas pipe lines, sewerage etc.
 - b. The depth of boring should be such as to clear any underground utilities/obstacles. However in no case the depth of boring be less than 2m from the road surface.
 - c. In horizontal and vertical boring the system should be capable of going up to 10 mts below the ground level.
 - d. In a shift of 8 hrs at least 500(Five hundred) meter of drilling should be achieved.
 - e. As far as possible cable should be laid in drum lengths and cutting of cables should be avoided while laying along road .

2. Ground penetrating Radar survey and damage to Telephone cable and other underground utility services:

- (i) The contractor should collect all available information regarding underground services and take necessary care to protect them. He should also have sufficient arrangements to identify and protect such underground services.
- (ii) The contractor shall carry out ground penetrating Radar survey along the proposed cable route at his own cost to identify the underground services and for setting out the rules as directed by executive officer. The executive officer shall provide the route map to the contractor if available for plotting the existing utilities and setting the route for horizontal drilling. However, for safe drilling the contractor should make requisite inspection and test pits whenever necessary.

3. LIFTING OF PLB PIPE:

The PLB pipe will be handed over to the contractor at stores. The contractor is to lift the store from the store depot to the work site.

Guarding at work site is to be done by the contractor.

At the time of laying, jack and wheel should be used so that the pipe is not damaged.

The contractor is to make arrangement of water and power at the site of work

Permission for laying is to be taken by contractor from appropriate civic & road

authorities.

Digging of test pit and restoration of pits are to be done by the contractor.

4. Fixing of Route Indicators/Joint Indicators: Pits shall be dug 1 M. towards jungle side at every manhole for fixing of Route Indicator. In addition, Route Indicators are also required to be placed where O.F Cable changes directions like road crossing etc. The pits for fixing the indicator shall be dug for a size of 60 cms. X 60 cms. and 75 cms. (depth). The indicator shall be secured in upright position by ramming with stone and murrum up-to a depth of 60 cms. And concreting in the ratio of 1:2:4 (1: cement, 2: coarse sand, 4: stone aggregate 20 mm nominal size) for the remaining portion of 15 cms. Necessary curing shall be carried out for the concreted structure with sufficient amount of water for reasonable time to harden the structure. The route indicator shall be painted with primer before painting with oil paint. The material used should bear ISI mark. The size of each written letter should be at least 3.5 cms. The colours of painting is yellow for Route Indicator and colour of sign writing white for Letters. The numbering scheme for route indicators will be Joint No./Route Indicators No. for that joint. For example 2/6 indicator means 6th route indicator after 2nd joint.

BSNL reserves the right to order the job of planting and painting the Route Indicators also to the Cable blowing contractor at the **Prefixed rate**. The Route Indicators will be supplied by BSNL. However, no additional payment will be done for Joint Indicators planting/painting as they are covered under the scope of blowing work.

8. DOCUMENTATION :

The documentation, consisting of the following shall be prepared exchange to exchange for intra SSA OFC links and for each section in case of Inter SSA/National Long Distance routes.

i) Route Index Diagrams – General :

This diagram shall consist of pipe Route Details on Geographical Map drawn to scale with prominent land marks and alignment of pipe with reference to road. This shall be prepared on A-3 sheets of 80 GSM.

ii) Route Index Diagrams – Profile :

These diagrams shall contain: Make and size of the pipe, Offset of pipe from center of the road at every 10 metres, Depth profile of pipe at every 10 metres; Details of protection with type of protection depicted on it, Location of culvert and bridges with their lengths and scheme of laying of PLB Pipe/coil thereon, Important landmarks to facilitate locating the pipe in future and Location of pulling manholes.

These diagrams shall be prepared on A-4 sheets of 80 GSM. On one sheet profile of maximum 400 metres shall be given to ensure clarity.

All the diagrams (i) & (ii) shall bear the signatures of the contractor, the SDE-Site-in-charge as a proof of accuracy of the details. The diagrams shall be bound in A-4 size book with cover. The cover sheets shall be of 110 GSM and laminated. The front cover shall have the details: Name of the SSA/Project Organization, Name of the OFC Link, Name of the Contractor, Date of commencement of work & Date of completion of work

For each route/section, 6 sets of above mentioned document shall be submitted.

9. SAFETY PRECAUTION:

i) Safety Precautions when excavating or working in excavations close to electric cables. The Engineer-in-charge of the work should get full information from Electricity undertaking regarding

any electric cables, which are known or suspected to exist near the

Proposed excavation and unless this is done, excavation should not be carried out in the section concerned. The electricity undertaking should be asked to send a representative and work should be preceded with close consultation with them.

Only wooden handled hand tools should be used until the electric cables have been completely exposed. A cover slab of concrete, brick or stone from above should usually be used to protect powerCables, not laid in conduits. They may or may not be protected on the sides. It is safer, therefore, always to drive the point of the pickaxe downwards then uncovering a cable, so that there is less chance of missing such warning slabs. No workman should be permitted to work alone where thereare electric cables involved. At least one more man should be working nearby so that help can be given quickly in case of an accident. If disconnection of power could be arranged in that section it will be better. No electric cables shall be moved or altered without the consent of the Electric Authority and they should be contacted to do the needful. If an electric cable is damaged even slightly, it should be reported to the Electric Authority and any warning bricks disturbed during excavation should bere placed while back filling the trench. Before driving a spike into the ground, the presence of other underground properties should be checked. Information on plans regarding the location of power cables need not to be assumed as wholly accurate. Full precautions should be taken in the vicinity until the power cable is uncovered. All electric cables should be regarded as being live and consequently dangerous. Any power is generally dangerous, even low voltage proving fatal in several cases.

ii) Electric shock-Action and treatment:

Free the victim from the contact as quickly as possible. He should be jerked away from the live conductors by dry timber, dry rope or dry clothing. Care should be taken not to touch with bare hands as his body may be energized while in contact. Artificial respiration should begin immediately to restore breathing even if life appears to be extinct. Every moment of delay is serious, so, in the meanwhile, a doctor should be called for.

Safety precautions while working in Public Street and along railway lines where a road or footpath isto be opened up in the course of work, special care should be taken to see that proper protection is provided to prevent any accidents from occurring. Excavation work should be done in such a manner that it will not unduly cause inconvenience to pedestrians or occupants of buildings or obstruct roadtraffic. Suitable bridges over open trenches should be so planned that these are required for the minimum possible time. Where bridges are constructed to accommodate vehicular traffic and is done near or on railway property, it should be with the full consent and knowledge of the competent railway authorities.

iii) Danger from falling material:

Care should be taken to see that apparatus, tools or other excavating implements or excavated materials are not left in a dangerous or insecure position so as to fall or be knocked into the trench thereby injuring any workman who may be working inside the trench.

iv) Care when working in Excavations:

Jumping into a trench is dangerous. If it is deep, workmen should be encouraged to lower themselves. Workers should work at safe distance so as to avoid striking each other accidentally with tools. If the walls of the trench contain glass bits, corroded wire or sharp objects they should be removed carefully. If an obstruction is encountered, it should be carefully uncovered and protected if necessary. Care must be taken to see that excavated material is not left in such a position that it is likely to cause any accident or obstruction to a roadway or waterway. If possible the excavated material should be put between the workmen and the traffic without encroaching too much on the road.

v) Danger of cave in:

When working in deep trenches in loose soil, timbering up/shoring the sides will prevent soil subsidence.

The excavated material should be kept at sufficient distance from the edge of the trench or pit. Vehicles or heavy equipment must not be permitted to approach too close to the excavation. When making tunneled opening, it should be ensured that the soil is compact enough to prevent cave in even under adverse conditions of traffic. Extra care should be taken while excavating near the foundations of buildings or retaining walls. In such cases, excavation should be done gradually and as far as possible in the presence of the owners of the property.

vi) Protection of Excavations:

Excavations in populated areas, which are not likely to be filled up on the same day should be protected by barriers or other effective means of preventing accidents and the location of all such openings must in any event be indicated by red flags or other suitable warning signs. During the hours from dusk to dawn, adequate number of red warning lamps should be displayed. Supervisory officers should ensure that all excavations are adequately protected in this manner as serious risk and responsibility is involved. Notwithstanding adoption of the above-mentioned precautions, works involving excavations should be so arranged as to keep the extent of opened ground and the time to open it to a minimum

vii) Precautions while working on roads:

The period between half an hour after sun-set and half an hour before sunrise, and any period of fog or abnormal darkness may also be considered at night for the purpose of these instructions, for the purpose of providing the warning signs. Excavation liable to cause danger to vehicles or the public must at all times be protected with fencing of rope tied to strong uprights or bamboo poles at a suitable height or by some other effective means. Any such temporary erection which is likely to cause obstructions and which is not readily visible should be marked by posts carrying red flags or boards with a red back-ground by day and by continuously lighted lamps at night.

The flags and the lamps should be placed in conspicuous positions so as to indicate the pedestrians and drivers of vehicles the full expanse i.e. both width and length of the obstruction. The distance between lamps or between floors should not generally exceed 1.25m along the width and 6m along length of the obstruction in non-congested area, but 4 meters' along the length in congested areas. If the excavation is extensive, sufficient notice to give adequate warning of the danger should be displayed conspicuously not less than 1.25m above the ground and close to the excavation. Where any excavation is not clearly visible for a distance of 25m to traffic approaching from any direction or any part of the carriage way of the road in which the excavation exists, a warning notice should be placed on the side or edge of all such roads from which the excavation or as near the distance as is practicable but not less than 10m from the junction of an entering or intersecting road in which the excavation exists. All warnings, in these should have a red background and should be clearly visible and legible. All warning lamps should exhibit a red light, but white lights may be used in addition to facilitate working at night. Wherever required a passage for pedestrians with footbridge should be provided. At excavations, cable drums, tools and all materials likely to offer obstructions should be properly folded, round and protected. This applied to jointer's tents as well. Leads, hoses etc. stretched and across the carriageway should be guarded adequately for their own protection and also that of the public.

viii. Traffic Control :

The police authorities are normally responsible for the control of traffic and may require the setting up of traffic controls to reduce the inconvenience occasioned by establishment of a single line of traffic due to restriction in road width or any other form of obstruction caused by the work. As far as possible, such arrangements should be settled in advance. If there are any specific regulations imposed by the local authorities, these should be followed.

ix. Work along Railway Lines:

Normally all works at Railway crossing is to be done under supervision of the railway authorities concerned, but it is to be borne in mind that use of white, red or green flags by the Departmental staff is

positively forbidden to be used when working along a railway line as this practice may cause an accident through engine drivers mistaking them for railway signals. When working along a double line of railway, the men should be warned to keep a sharp look on both the “UP” and “DOWN” lines to avoid the possibility of any accident when trains pass or happen to cross one another near the workspot.

x. Procedure and Safety precautions for use of explosives during blasting for Trenching:

In areas where the cable trench cannot be done manually on account of boulders and rocks, it is necessary to blast the rocks by using suitable explosives. The quality of explosive to be used depends on the nature of the rocks and the kind of boulders. A few types of explosive fuses and detonators normally used for making trenches for cable works are detailed as: Gun powder, Nitrate, Mixture, Gelatin, Safety Fuse, Electric Detonator, and Ordinary Detonator.

i) Procedure :

A detailed survey of the route is to be done to assess the length of the section where trenching is to be done with the help of blasting. A route diagram of the rocky section may be prepared indicating the length of the route where the explosives are to be used. For the purpose of obtaining license, a longer length of route should be given in the application as in many cases, after digging, rocks appear where blasting was not initially anticipated.

Next a license will have to be obtained for use and storing of explosive in that section. If the area falls under a police commissioner, the authority for granting such license is the police commissioner of the concerned area. When the route does not fall in the jurisdiction of a police commissioner, the authority for issuing license is the District Magistrate.

The concerned authority should be applied in prescribed form with a route map. The concerned authority will make an enquiry and issue a license for using/storing explosives for cable trenching work. Such license will be valid for 15 days only. The license should be got renewed if the blasting operation need to be extended. Once the license is granted, it is the responsibility of the holders of the license for the proper use of explosives, its transportation and storing.

ii) Method of using :

The safest explosive is the gelatin and electric detonator. Gelatin is in the form of a stick. Electric detonator is a type of fuse used for firing the explosive electrically. Holes are made at suitable intervals on rocky terrain or boulders either by air compressor or by manual chipping. The depth of the holes should be 2 to 3 ft. Fill up the holes with small quantity of sand for about 6”. First the electric detonator is to be inserted into the gelatin and the gelatin is to be inserted into the holes keeping the + ve and –ve wirings of electric detonators outside the holes. Again refill the holes with sand. These + ve and –ve insulated wires of detonator are then extended and finally connected to an EXPLODER kept at a distance of not less than 100m. Now the explosive is ready for blasting. But, before connecting wires to exploder for blasting, all necessary precautions for stopping the traffic, use of red flags, exchange of caution signals, etc., should be completed and only then Exploder should be connected and operated.

iii) Operation of exploder (IDL schaffler type 350 type exploder) :

The type 350 blasting machine consists of a bearing block with blasting machine system and the explosion proof light – alloy injection moulded housing. The exploder is held with the left hand. The twist handle is applied to the drive pin, clapped with the right hand turned in the clock wise direction in continuous measurements at the highest speed from the initial position until it reached to a stop. At this stage an indication lamp will glow. When the indication lamp glows, “press button switch” should be pressed. This will extend the electric current to detonator and gelatin will be detonated. The rock will be blasted out of the trench. Number of holes can be blasted in a single stroke by connecting all such detonators in series connection and finally to the exploder. After blasting, again mazdoors are engaged on the work to clear the debris. If the result of the first blasting is not satisfactory, it should be repeated

again on the same place.

iv) Warning :

There may be two reasons for unsatisfactory results of the blasting :

- a) Misfire of gelatin due to leakage for current from detonator.
- b) Over loading because of overburden

Never pull the broken wire pieces from the holes in such cases. Attempt should not be made to re-blast the misfired gelatin. The safest way is to make a fresh hole by its side and put fresh gelatin in that hole and blast it.

10. Precautions :

The abstract of Explosives Rules 1983 which are relevant to our work is given below: Restriction of delivery and dispatch of explosives :

No person shall deliver or dispatch any explosives to any one other than a person who is the holder of a license to possess the explosives or the agent of holder of such a license duly authorized by him in writing on his behalf. OR is entitled under these rules to possess the explosives without a license.

The explosives so delivered or authorized shall in no case exceed the quantity, which the person to whom they are delivered or authorized to possess with or without a license under these rules.

No other shall receive explosives from any person other than the holder of a license granted under these rules. No person shall receive from or transfer explosives to any person for a temporary storage or safe custody in a licensed premise unless prior approval is obtained from the Chief Controller.

A person holding license for possession of explosives granted under these rules shall store the explosives only in premises specified in the license.

11. Protection from Lightning During Storing :

Every magazine shall have attached there to one or more efficient lightning conductors designed and erected in accordance with the specification laid down in Indian Standard Specifications No. 2309 as amended from time to time. The connections to various parts of earth resistance of the lightning conductor terminal on the building to the earth shall be tested at least once in every year by a qualified electrical engineer or any other competent person holding a certificate of competency in this behalf from the State Electricity Department. A certificate showing the results of such tests and the date of the last test shall be hung up in conspicuous place in the building.

i) Precautions during thunder-storm:

When a thunder-storm appears to be imminent in the vicinity of a magazine or store house every person engaged in or around such magazine and store house shall be withdrawn to a safe distance from such magazine or store house and the magazine and store house shall be kept closed and locked until the thunder storm has ceased or the threat of it has passed.

ii) Maintenance of records :

Every person holding a license granted under these rules for possession, sale or use of explosives shall maintain records in the prescribed forms and shall produce such record on demand to an Inspection Officer.

iii) Explosives not be kept in damaged boxes :

The licensee of every magazine or store house shall ensure that, the explosives are always kept in their original outer package. In case, the outer package gets damaged so that the explosives contained therein cannot be stored or transported, such explosives shall be repacked only after the same are examined by controller of explosives.

iv) Storage of explosives in excess of the licensed quantity :

The quantity of any kind of explosives kept in any licensed magazine or store house shall not exceed the quantity entered in the license against such kind of explosives. No explosives in

excess of the licensed quantity shall be stored in the magazine or store house unless a permit in this behalf is obtained from the licensing authority by a letter or telegram.

v) Precautions to be observed at Site :

The electric power at the blasting site shall be discontinued as far as practicable before charging the explosives. No work other than that associated with the charging operations shall be carried out within 10 meters of the holes unless otherwise specified to the contrary by the licensing authority. When charging is completed, any surplus explosive detonators and fuses shall be removed from the vicinity of the hole and stored at a distance which should prevent accidental detonation in the event of a charge detonating prematurely in any hole. The holes which have been charged with explosives shall not be left unattended till the blasting is completed. Care shall be taken to ensure that fuse or wires connected to the detonation are not damaged during the placing of stemming materials and tamping.

vi) Suitable warning procedure to be maintained :

The licensee or a person appointed by the licensee to be in charge of the use of explosives at the site shall lay down a clear warning procedure consisting of warning signs and suitable signals and all persons employed in the area shall be made fully conversant with such signs and signals.

vii) Precautions to be observed while firing :

The end of the safety fuse if used in place of a detonator should be freshly cut before being lighted. The exploders shall be regularly tested and maintained in a fit condition for use in firing. An exploder shall not be used for firing a circuit above its rated capacity. The electric circuits shall be tested for continuity before firing. All persons other than the shot-firer and his assistant, if any, shall be withdrawn from the site before testing the continuity.

For the purpose of jointing, the ends of all wires and cables should have the insulation removed for a maximum length of 5 cms. And should, then be made clear and bright for a minimum length of 2.5 cms. And the ends to be joined should be twisted together so as to have a positive metal contact. Then these should be taped with insulation to avoid leakage when in contact with earth.

In case of blasting with dynamite or any other high explosive, the position of all the bore holes to be drilled shall be marked in circles with white paint. These shall be inspected by the Contractor's agent. Bore holes shall be of a size that the cartridge can easily pass down. After the drilling operation, the agent shall inspect the holes to ensure that drilling has been done only at the marked locations and no extra hole has been drilled. The agent shall then prepare the necessary charge separately for each bore hole. The bore holes shall be thoroughly cleaned before a cartridge is inserted. Only cylindrical wooden tamping rods shall be used for tamping. Metal rods or rods having pointed ends shall never be used for tamping. One cartridge shall be placed in the bore hole and gently pressed but not rammed down. Other cartridges shall then be added as may be required to make up the necessary charge for the borehole. The top most cartridge shall be connected to the detonator which shall in turn be connected to the safety fuses of required length. All fuses shall be cut to the length required before being inserted into the holes. Joints in fuses shall be avoided. Where joints are unavoidable, a semi-circular niche shall be cut in one piece inserted into the niche. The two pieces shall then be wrapped together with string. All joints exposed to dampness shall be wrapped with rubber tape.

The maximum of eight bore holes shall be loaded and fired at one occasion. The charges shall be fired successively and not simultaneously. Immediately before firing, warning shall be given and the agent shall see that all persons have retired to a place of safety. The safety fuses of the charged holes shall be ignited in the presence of the agent, who shall see that all the fuses are properly ignited.

Careful count shall be kept by the agent and others of each blast as it explodes. In case all the charged bore holes have exploded, the agent shall inspect the site soon after the blast but in case of misfire the agent shall inspect the site after half an hour and mark red crosses (X) over the holes which have not exploded. During his interval of half an hour, nobody shall approach the misfired holes. No driller shall

work near such bore until either of the following operations have been done by the agent for the misfired boreholes.

The contractor's agent shall very carefully (when the tamping is a damp day) extract the tamping with a wooden scraper and withdraw the primer and detonator.

The holes shall be cleaned for 30 cm of tamping and its direction ascertained by placing a stick in the hole. Another hole shall then be drilled 15 cm away and parallel to it. This hole shall be charged and fired. The misfired holes shall also explode along with the new one. Before leaving the site of work, the agent of one shift shall inform another agent relieving him for the next shift, of any case of misfire and each such location shall be jointly inspected and the action to be taken in the matter shall be explained to the relieving agent.

The Engineer-in-charge shall also be informed by the agent of all cases of misfire, their causes and steps taken in that connection.

12. General Precautions:

For the safety of persons red flags shall be prominently displayed around the area where blasting operations are to be carried out. All the workers at site, except those who actually ignite the fuse, shall withdraw to a safe distance of at least 200 meters from the blasting site. Audio warning by blowing whistle shall be given before igniting the fuse.

Blasting work shall be done under careful supervision and trained personnel shall be employed. Blasting shall not be done within 200 meters of an existing structure, unless specifically permitted by the Engineer-in-charge in writing.

i) Precautions against misfire:

The safety fuse shall be cut in an oblique direction with a knife. All saw dust shall be cleared from inside of the detonator. This can be done by blowing down the detonator and tapping the open end. No tools shall be inserted into the detonator for this purpose.

If there is water present or if the borehole is damp, the junction of the fuse and detonator shall be made water tight by means of tough grease or any other suitable material. The detonator shall be inserted into the cartridge so that about one-third of the copper tube is left exposed outside the explosive. The safety fuse just above the detonator shall be securely tied in position in the cartridge. Water proof fuse only shall be used in the damp borehole or when water is present in the borehole.

If a misfire has been found to be due to defective fuse, detonator or dynamite, the entire consignment from which the fuse, detonator or dynamite was taken shall be got inspected by the Engineer-in-charge or his authorized representative before resuming the blasting or returning the consignment.

ii) Precaution against stray currents: Where electrically operated equipment's is used in locations having conductive ground or continuous metal objects, tests shall be made for stray current to ensure that electrical firing can proceed safely.

.C.C ROUTE INDICATOR

DIAGRAMS OF RCC ROUTE INDICATORS

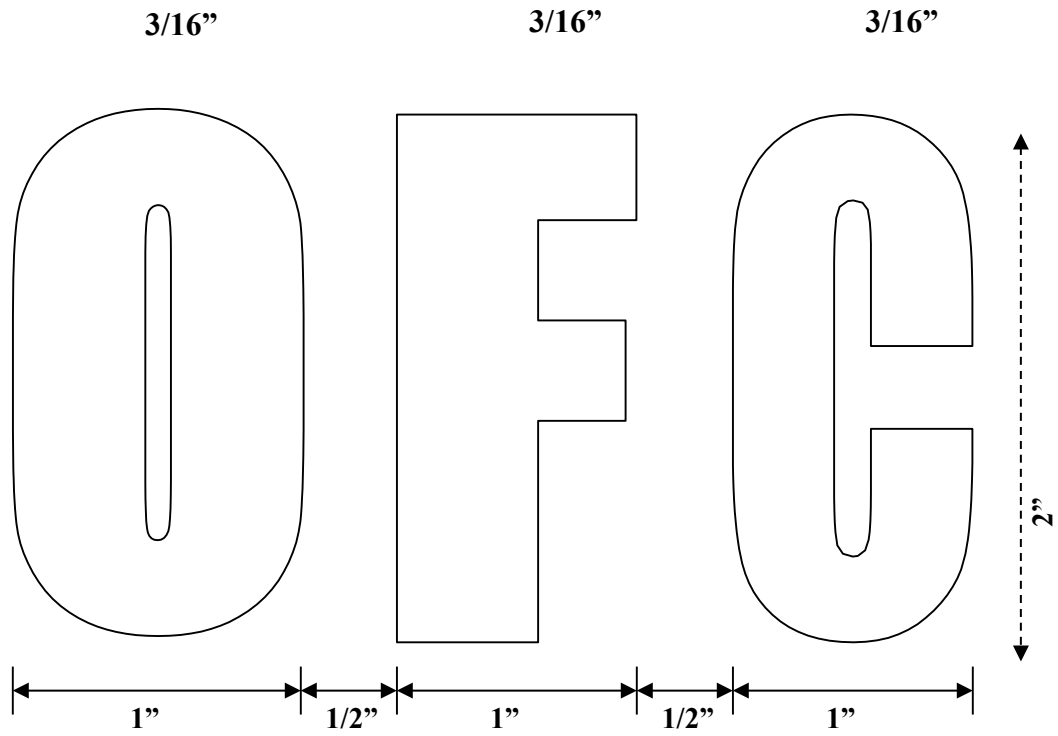

ELEVATION

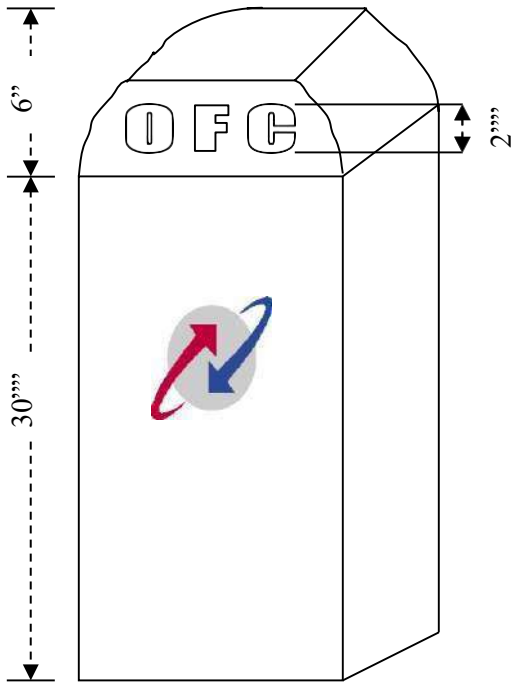

Reinforcement Details

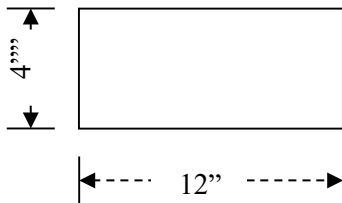
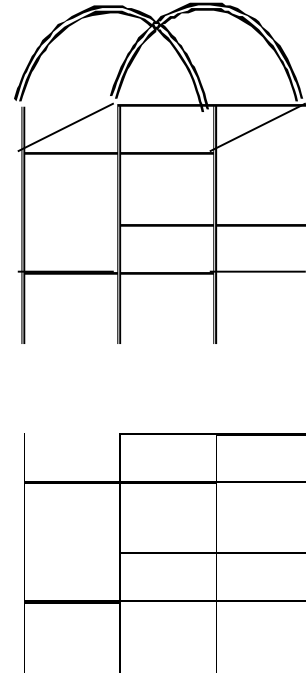

PLAN

Note:

1. Concrete Mix should be One Cement, 1½ Sand and 3 Jelly (i.e. 1:1½:3)
 2. Finish should be smooth for a distance of 18" from Top.
- Curing is to be done strictly for **21 Days** as per the standards.

Size of Letters:

3. Height: 2"
Width: 1"

Items to be supplied with the logo of "OFC" on both sides of the Route Indicators.

I/727458/DIAGRAMS OF RCC CHAMBERS with BOTTOM & TOP COVERS

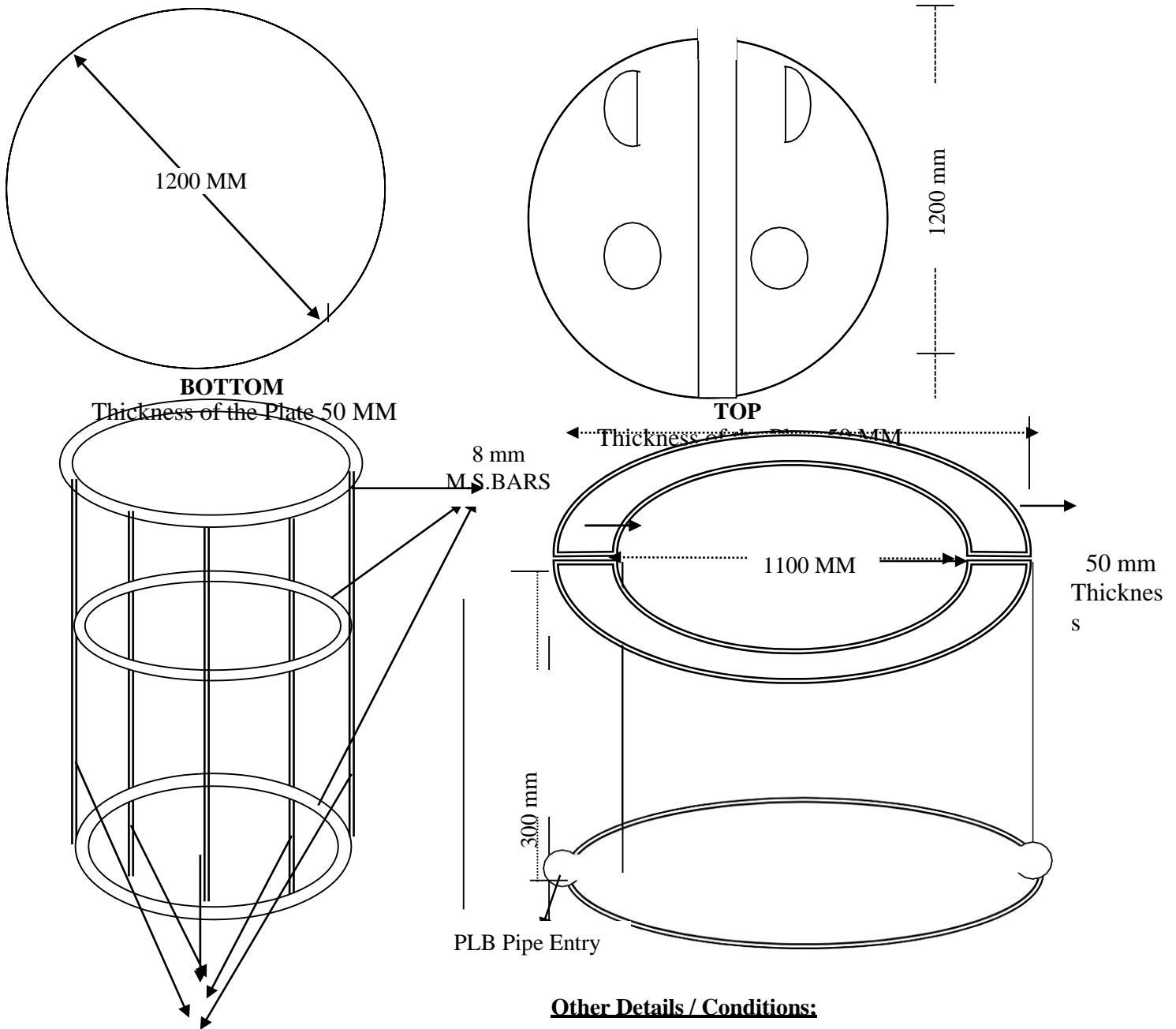

Other Details / Conditions:

- a) Concrete Mix: 1: 2: 4 (1 Cement: 2 Coarse Sand: 4 stone)
- b) Curing is to be done strictly for **21 Days** as per the standards.
- c) Finishing: Smooth

END OF SECTION XIII

**Section XIV
ANNEXURE-A
NEAR RELATIONSHIP CERTIFICATE**

1. The tenderer or his staff shall not be a working officer/official of the BSNL. The near relatives of all BSNL executive in the concerned territorial circle or non-executive employees working in the concerned BA of the territorial circle in which the work is stipulated under this contract either directly recruited or on deputation are prohibited from participation in this tender. The near relatives for this purpose are defined as:

- a) Members of a Hindu Undivided family.
- b) They are husband and wife.
- c) The one is related to the other in the manner as father, mother son(s), son's wife (daughter-in-law) Daughter(s) & daughter's husband (son-in-law) brother(s) & brother's wife, sister(s) & sister's husband (brother-in-law).

2. **The tenderer (s) should give a certificate to the effect that none of his/her relatives as defined above are working in the BA/Territorial Circle in which the work is stipulated under this contract.** In case of proprietorship firm, the certificate will be given by the proprietor, for partnership firm certificate will be given by all the partners and in case of limited company by all Directors of the Company. Any breach of these conditions by the company or firm or any other person, the tender work will be cancelled and earnest money /security deposit will be forfeited at any stage whenever it is noticed. The BSNL will not pay any damages to the company or firm or concerned person. The company or firm or the person may also be debarred for further participation in the concerned unit.

CERTIFICATE

I.....S/o.....

R/o.....

Here by certify that none of my relative(s) as defined above is/are employed in the **BA/Territorial Circle** in which the work is stipulated under this contract. In case at any stage, it is found that the information given by me is false/incorrect, BSNL shall have the absolute right to take any action as deemed fit/without any prior intimation to me"

DATE _____

SIGNATURE OF TENDERER WITH SEAL

Section XIV
ANNEXURE-B
Non-Black listing declaration
(To be given on Company Letter Head)

Date:

To,

Sub: Declaration for Non-Blacklisting-Reg

Tender Reference No: _____

Name of Tender / Work: -----

Dear Sir,

We hereby declare that we are not black listed by any Central/ State Government/ agency of Central/ State Government of India / Public Sector Undertaking/any Regulatory Authorities in India/BSNL/ MTNL/ TCIL/ ITI/RITES/HCL/PGCIL/RailTel/GST/any other TSP/ISP for any kind of fraudulent activities.

Yours Faithfully,
(Signature of the Bidder, with Official Seal)

Section XIV
ANNEXURE-C
CLAUSE-BY-CLAUSE COMPLIANCE STATEMENT

S.No	Clause	Compliance
(A)	(B)	(C)
1	All clauses of Scope of the work of Section-3	
2	All clauses of Schedule of Requirements (SOR) of Section-3	
3	All clauses of General Commercial Conditions of Section-5 Part A	
4	All clauses of Special Commercial Condition of Contract of Section-5 Part B	

- i) The clause-by-clause compliance statement should be given as per clause 11.2 of Section-4 Part A and clause 31.1 of Section-4 Part A.
- ii) The bidder should mention **'FULLY COMPLIED' in the column 'C' above**; otherwise a statement of deviation may be submitted as per clause 11.2 of Section-4 Part A and clause 31.1 of Section-4 Part A.

ANNEXURE-D
NO DEVIATION STATEMENT

S.No	Clauses	Compliance
(A)	(B)	(C)
1	All clauses of Scope of the work of Section-3	
2	All clauses of Schedule of Requirements (SOR) of Section-3	
3	All clauses of General Commercial Conditions of Section-5 Part A	
4	All clauses of Special Commercial Condition of Contract of Section-5 Part B	

- i) The 'No deviation statement' should be given as per clause 11.2 of Section-4 Part A and clause 31.1 of Section-4 Part A.
- ii) The bidder should mention **'NO DEVIATION' in the column 'C' above**; otherwise a statement of deviation may be submitted as per clause 31.1 section-4 Part A.

ANNEXURE-E

UNDERTAKING & DECLARATION

For understanding the terms & condition of Tender & Specification of work

a) Certified that:

1. I/ Wehave read, understood and agree with all the terms and conditions, specifications included in the tender documents & offer to execute the work at the rates quoted by us in the tender form.

2. If I/ We fail to enter into the agreement & commence the work in time, the EMD/ SD deposited by us will stand forfeited to the BSNL.

b) The Tenderer hereby covenants and declares that:

1. All the information, Documents, Photo copies of the Documents/ Certificates enclosed along with the Tender offer are correct.

2. If anything is found false and/or incorrect and/or reveals any suppression of fact at any time, BSNL reserves the right to debar our tender offer/ cancel the LOA/ Purchase/ work order if issued and forfeit the EMD/ SD/ Bill amount pending with BSNL. In addition, BSNL may debar the contractor from participation in its future tenders.

Date:

Signature of TendererPlace:

.....
Name of Tenderer

Along with date & Seal

END OF SECTION XIV

Section XV**Annexure-B****Proforma for Experience Certificate**

Name and address of the issuing office
--

No: _____ Dated _____

Subject: Experience certificate for optical fibre cable construction work.

It is certified that M/s _____

having office at _____

whose Proprietor(s)/Partner(s)/Director(s) are _____

have successfully carried out **optical fibre cable construction work** for the amount mentioned hereunder. It is certified that these amounts have been paid to the above mentioned contractor.

S.N.	Period during which payments Made		Contract No(s).	Amount paid (In Rs.)
	From	To		
1.	01-04-YYYY	31-03-YYYY		

AGM/AO/DDO/ Equivalent Officer responsible for
Maintaining contractor's Ledger
Signature of office seal

----- END OF SECTION XV -----

Section XVI

Annexure-C

Declaration about Genuineness of Documents/Certificates

(to be duly filled, signed, stamped, scanned and submitted with other documents as per clause-7 of Section-IV)

I/We..... hereby declare that the information furnished in the bid in response to the **NIT No.** -----

-
-----is true and correct. I/we verify the genuineness and correctness of all documents, including experience certificates attached with the bid submitted electronically or as a hard copy. Further I also declare that I have submitted the tender document digitally signed, without any additions/deletions/modifications, as a token of having read, understood and accepted the terms and conditions therein. I am also aware that I shall be held responsible in case any document attached is found false/forged/fabricated/tempered/manipulated at any stage and the BSNL is fully competent to take any action against me/my firm as deemed fit in accordance with the terms and conditions of the contract and law of the land.

Place: Signature of tenderer / Authorized signatory.....

Date: Name of the tenderer.....

Seal of the tenderer

----- END OF SECTION XVI -----

SECTION XVII

SAMPLE APPLICATION FOR DEPTH RELAXATION IN CASE OF ACHIEVING LOWER DEPTH

To
The Engineer-in-Charge,
.....

Sub : Approval for lower depth than 165/135/90 cms (depending on the terrain and method of execution as applicable)

Ref : Work Order No.....

Sir,

In the following section lengths the normal depth of(as prescribed) could not be achieved due to reasons stated against each section vide above reference work order. Your approval is requested.

Sl.No	Section No.	Location From	Location To	Length in Mtrs.	Actual Depth Achieved in Mtrs.	Reason
1						
2						
3						

Yours faithfully,

Name of the Bidder with address & date.

Recommendation of the Site-in-Charge.

----- END OF SECTION XVII -----

SECTION XVIII**RATE OF EMPTY CABLE DRUM**

These are the rate of the empty cable drums which have to be deducted from contractor bills as per tender document.

<i>Sl.No.</i>	<i>Particulars of drum</i>	<i>Rate of disposal</i>
1	Optical Fibre cable drum 24F/12F/48F	Rs.100/- per empty cable drum
2	Optical Fibre cable drum 96F/144F/288F	Rs.200/- per empty cable drum

Note: -These are fixed rates and no variations shall be acceptable from these rates.

Signature of the Bidder with seal

----- END OF SECTION XVIII -----

SECTION XIX**Schedule of quantities stipulated under this tender and rates**

Section-1: Section Wise Schedule of Quantities and Estimation of Cost of Works put to Tender Name: Laying PLB pipe/ Duct and Associated works by Open Trench Method/Trenchless Technology, Optical Fibre Cable Pulling/Blowing and splicing works etc., for Sri City Check post BBNL BJC- Post Office Sri City BSNL BJC, in Chittoor BA, A.P-517501

1	NIT No and Date	NIT No APCO-23/11(13)/26/2024-MM AND IT DATED 23/08/2024		
2	Name of the work	Laying PLB pipe/ Duct and Associated works by Open Trench Method/Trenchless Technology, Optical Fibre Cable Pulling/Blowing and splicing works etc.		
3	Name of Sections	Sri City Check post BBNL BJC- Post Office Sri City BSNL BJC, in Chittoor BA, A.P-517501		
4	Section Number	1		
5	Section Length (approx.)	2100 mtrs		
6	Estimated cost (inclusive of GST)	Rs 8,32,957.28/		
7	Time Period	42 Days		
8	Schedule of Estimated Rate	Type of Work	Approx.Length in mtrs	Estimated Rate per meter (in Rs.) (exclusive of GST)
		Open Trenching	1000	200.12
		HDD	1100	400

SECTION XX
Financial Bid
Schedule for Quoting the Rates

To,
The AGM(Tenders),
O/o CGMT
BSNL Bhavan Vijayawada

Sub: Our bid for **Section-1:** Laying PLB pipe/ Duct and Associated works by Open Trench Method/Trenchless Technology, Optical Fibre Cable Pulling/Blowing and splicing works etc., for Sri City Check post BBNL BJC- Post Office Sri City BSNL BJC, in Chittoor BA-Reg

NIT No APCO-23/11(13)/26/2024-MM AND IT DATED 23/08/2024

Route Length: 2100 mtrs

Dear Sir,

Having examined the tender documents, terms and conditions stipulated therein, specifications of work etc., we the under signed offer to execute the Optical Fiber Cable construction work including Laying PLB pipe/ Duct and Associated works by Open Trench Method/Trenchless Technology, Optical Fibre Cable Pulling/Blowing and splicing works etc., for Sri City Check post BBNL BJC- Post Office Sri City BSNL BJC, in Chittoor BA in this tender in conformity with the said specifications and conditions of contract, at the percentage on route wise schedule of quantities and estimation of cost of works put to tender mentioned in the tender document (Section-XIX) quoted as under:

Sl.	Item Description	Quantity (to be mentioned by Circle)	Unit	Basic Estimated Cost per Mtr (in Rs.) Excl of GST	Quoted unit rate without GST (in Rs.)	GST rate	Total cost of item without GST	Total cost inclusive of GST	SAC code
A	B	C	D		E	F	G =C x E	H= G+G x F	I
1	Open Trenching	1000	Mtr	200.12					
2	HDD	1100	Mtr	400					
	Total in Figures								

Note: 1. Tenderer should quote the rates keeping in view that quoted rates are inclusive of all charges and levies but exclusive of Goods & Service tax (GST). Goods & Service tax (GST) will be paid extra, as applicable.

2. We agree to abide by this bid for a period of 180 days from the date of opening of qualifying bid and it shall remain binding upon us and may be accepted at any time before the expiry of that period.

Dated...../...../.....

Signature of the tenderer.....

Name of Tenderer.....

**ANNEXURE - 1
DEED OF INDEMNITY**

This **DEED OF INDEMNITY** is executed on this day, by <<**Name of the Bidder**>>, a company/ firm registered under the(Applicable acts, as the case may be) (hereinafter referred to as the **Bidder**) and having its registered office at <<Address of the Bidder>> acting through << Authorized Signatory>> is hereinafter, for the purposes of this Deed of Indemnity.

TO AND IN FAVOUR OF

Bharat Sanchar Nigam Limited, through the BSNL.....Office (hereinafter referred to as the **Purchaser** which expression shall unless repugnant to the context or meaning thereof mean and be deemed to include its authorized representatives and permitted assigns) **on the Other Part.**

WHEREAS

(a) The Purchaser had invited bids *vide* their Tender Enquiry No (hereinafter referred to as 'Tender') for the purpose of.....

(b) The Bidder had submitted its bid/ proposal dated (hereinafter referred to as the 'Bid') for the provision of such services in accordance with its proposal as set out in its Bid and in accordance with the terms and conditions of the Tender.

(c) The Bidder has in order to comply with the terms of the Tender agreed to execute the Deed of Indemnity on such terms and conditions more fully mentioned below.

NOW THIS DEED OF INDEMNITY WITNESSETH AS FOLLOWS:

1. The Bidder shall, in consideration of the Purchaser making payment under and in accordance with the Tender Document, hereby agrees to indemnify the Purchaser against any costs, loss, damages and claims from third parties or liabilities suffered by the Purchaser and directly arising out of the following reasons:
 - a. Any illegal or unauthorized use or in connection with any claim or proceedings relating to any breach or violation of any permission/license terms by the Bidder or any of its sub- contractor in the process of fulfillment of required obligations during contract period.
 - b. The Bidder shall protect, defend, indemnify and hold harmless to BSNL and its employees from and against any and all liabilities, damages, fines, penalties and cost (including legal costs and disbursements) arising from:
 - I. Any breach of any statute, regulation, direction, orders or standards from any Governmental body, Agency or regulator issued with respect to the product /services being supplied/provided under this Tender.
 - II. Any claim made by third parties arising out of the use of the services of BSNL being provided using the equipment/services supplied under the Tender to the extent these are attributable solely to the poor quality or non-compliance of the products/services to the respective specifications.
 - III. Any claims arising from other utility / service providers in connection with interruptions or degradation of their services due to services provided by bidder under this Tender.

I/727458/2024

1. The bidder also declares that in case bidder is blacklisted by GST Authorities in future & which results in loss of Input Tax Credit (ITC) to BSNL, then BSNL shall have right to recover any such loss of ITC arising on account of such black-listing.
2. This Deed of Indemnity shall stand terminated on expiry of or early termination of the contract period as envisaged in the above said Tender requirement.
3. The Deed of Indemnity shall constitute the entire indemnity provided by the Bidder for the indemnities asked in said Tender.
4. This Deed of Indemnity shall be governed by and construed in accordance with Indian law.

(Authorized Signatory)

Date:

Place:

<< Name of the Bidder >>

Witness 1:

Witness 2:

ANNEXURE-2
CHECK LIST FOR THE BIDDERS

Please ensure that all documents are fully authenticated by the Authorized Signatory with his signature with official seal, as per the eligible bidder's criteria. Offer is liable to be rejected, if enclosed documents are not authenticated.

Documents forming part of the bid: -

Sl. No.	DOCUMENTS	Submitted / Not Submitted (If Not Applicable, reason in brief)
1	<p>Cost of the tender document (___/-)or A proof regarding valid registration with body specified by Ministry of Micro, Small & Medium Enterprise for the tendered items will have to be attached along with the bid. The address mentioned in the Registration Certificate & MSME Certificate must be the same. The enlistment certificate issued by MSME should be valid on the date of opening of tender.</p>	
2	<p>Bid Security in the form of Bank Guarantee for ₹_____-/- valid up to 180 days from the date of tender opening. Or A proof regarding valid registration with body specified by Ministry of Micro, Small & Medium Enterprise for the tendered items will have to be attached along with the bid. The address mentioned in the Registration Certificate & MSME certificate must be the same. The enlistment certificate issued by MSME should be valid on the date of opening of tender.</p>	
3	<p>Scanned copy of Bid Form in Section-II duly filled up and signed and Price Schedule in Section-XX to be filled online only and signed.</p>	
4	<p>Scanned copy of the documents, as applicable, in support of registration of the Company/Firm/Proprietorship:</p> <ul style="list-style-type: none"> ➤ The registration of the firm, authenticated copy of partnership deed in cases of partnership firm. ➤ Attested copy of Articles of Association duly registered with Registrar of Company affairs, in case of Limited/Pvt. Limited Company. <p>Duly executed Affidavit, stating that tenderer is the sole proprietor of the firm or any document issued by the taxation authorities stating that tenderer is the sole proprietor of the firm, in case of proprietorship firm.</p>	
5	<p>Scanned copy of Registered Power of Attorney (duly registered with sub registrar)/Resolution of Board of Directors, authorizing individual(s) including the person with whose DSC the tender is</p>	

I/727458/2024

	submitted on e-tendering portal (if and as applicable) as per Clause no. 11.3 of Section-IV .	
6	Scanned Copy of board resolution, authorizing a person for executing power of attorney in the name of person, who is signing the bid document.(In case of Company/Institution/Body Corporate)	
7	Scanned copy of the Experience Certificate(s) as per clause 2 of Section -I in the prescribed pro-forma(Annexure-B)	
8	Scanned copy of 'No Deviation' statement & Clause-by-Clause compliance statement as per Section XIV, Annexure-C & D respectively.	
9	Scanned copy of a list of all Board of Directors of the company (In case of Limited Company).	
10	Signed tender document on each and every page without any alternation/ digitally uploaded in PDF format with digital signature of the authorized signatory on the document without any alternation	
11	Scanned copy of Near Relationship Certificate as per Section XIV, Annexure-A	
12	A self- declaration along with the evidence that the bidder is not black listed by GST/BSNL authorities and MTNL/TCIL/ITI/RITES/HCL /PGCIL/RailTel/ any other Govt(Central/State) undertaking/ any other TSP/ISP as the case may be as per Section XIV, Annexure-B.	
13	Letter of Authorization to attend Bid opening event	
14	Valid PAN Card	
15	Valid Goods and Services Tax Registration Certificate (s)	
16	Undertaking and Declaration as per Section XIV, Annexure-E duly filled up and signed	
17	Tenderer's/Bidder's Profile as per Section-III duly filled up and signed.	
18	Indemnity Bond as per Annexure-1.	
19	Scanned copy of the valid EPF Registration Certificate.	
20	Scanned copy of the valid ESI Registration Certificate.	
21	Scanned copy of the valid GSTIN Registration Certificate.	
22	Scanned copy of Documents related to financial capabilities of the bidder as per clause 7.9 of Section -IV "Solvency certificate from the banker of the tenderer: <i>For works costing up to Rs. 20 lakhs-solvency certificate should be of Rs. 5 lakhs; For works costing more than 20 lakhs- solvency certificate should be of Rs. 10 lakhs. The solvency certificate shall not be older than 3 months from the date of issue of NIT.(or) last three years audited financial statements duly certified by CA should be submitted and last three financial years cumulative turnover must be greater than equal to Total estimated cost of Tender.</i> "	
23	Signed tender document on each and every page without any alternation/ digitally uploaded in PDF format with digital signature of the authorized signatory on the document without any alternation	
24	Scanned copy of duly completed Declaration about Genuineness of	

I/727458/2024

	Documents/Certificates as per Annexure-C.	
25	Scanned Copy of Income Tax Returns for Last 3 Years(2020-2021, 2021-2022, 2022-2023	
26	Any other supporting documents asked for in bid document.	

For and on behalf of M/s..... (Insert Name of Bidding Company)

.....

Signature and Name of the Authorized signatory of the

Company
Company rubber stamp/seal

Place:.....

Date:.....